

MECHANICAL DRAWING / REVISION LOG

NUMBER	NAME	DATE:	2/02/2021	ISSUE:	PERMIT	
						●
M001	MECHANICAL COVER SHEET					●
M101	MECHANICAL FIRST FLOOR REFLECTED CEILING PLAN					●
M102	MECHANICAL SECOND FLOOR REFLECTED CEILING PLAN					●
M103	MECHANICAL ROOF PLAN					●
M301	MECHANICAL SPECIFICATIONS					●
M401	MECHANICAL DETAILS					●
M601	MECHANICAL SCHEDULES					●
M602	MECHANICAL SCHEDULES					●

GENERAL NOTES

- ALL LOW PRESSURE BRANCH DUCTWORK (SUPPLY AND RETURN) SHALL BE PROVIDED WITH VOLUME DAMPERS.
- PROVIDE FIRE/SMOKE DAMPER AS REQUIRED BY CODE. SHEET METAL ACCESS DOORS AS WELL AS ACCESS DOORS IN FINISHED CONSTRUCTION SHALL BE PROVIDED FOR ALL DAMPERS.
- PROVIDE CEILING RADIATION DAMPERS FOR ALL CEILING PENETRATIONS OF FIRE RATED HORIZONTAL ASSEMBLIES.
- BORDER TYPES, COLOR, FINISHES, AND METHOD OF ATTACHMENT FOR ALL DIFFUSERS, GRILLES AND REGISTERS SHALL BE COORDINATED WITH THE ARCHITECTURAL CEILING DETAILS AND SPECIFICATIONS.
- THERMOSTAT SHOULD BE LOCATED 4'-0" A.F.F. AND 9" FROM EDGE OF DOOR U.O.N. FINAL LOCATIONS TO BE VERIFIED WITH THE ARCHITECT. COLOR TO BE SELECTED BY THE OWNER.
- REFER TO SCHEDULE SHEETS FOR THE DIFFUSER, GRILLE AND REGISTER SCHEDULES.
- THIS CONTRACTOR SHALL FIELD VERIFY ALL DIMENSIONS AND EXISTING CONDITIONS PRIOR TO PROCEEDING WITH ANY WORK. WHERE DISCREPANCIES OCCUR BETWEEN THESE DOCUMENTS AND EXISTING CONDITIONS, THE DISCREPANCY SHALL BE REPORTED TO THE OWNER AND/OR ENGINEER FOR EXPEDITING AND RESOLVE.
- ALL WORK SHALL BE PERFORMED IN A CLEAN AND WORKMANLIKE MANNER. CARE SHALL BE EXERCISED TO MINIMIZE ANY INCONVENIENCE OR DISTURBANCE TO OTHER AREAS OF THE BUILDING WHICH ARE TO REMAIN IN OPERATION. ISOLATE WORK AREAS BY MEANS OF TEMPORARY PARTITIONS AND/OR TARPS TO KEEP DUST AND DIRT WITHIN THE CONSTRUCTION AREA.

ABBREVIATIONS

AC	AIR CONDITIONING UNIT
AD	ACCESS DOOR
AFF	ABOVE FINISHED FLOOR
AHU	AIR HANDLING UNIT
AL	ACOUSTICAL LINING
ALD	AUTOMATIC LOUVER DAMPER
BDD	BACKDRAFT DAMPER
BI	BLACK IRON
BRD	BAROMETRIC RELIEF DAMPER
BR(G)	BOTTOM REGISTER OR GRILLE
CAV	CONSTANT AIR VOLUME
CC	COOLING COIL
CD	CEILING DIFFUSER
COD	CLEAN OUT DOOR
CP	CONDENSATE PUMP
CR(G)	CEILING REGISTER OR GRILLE
CRD	CEILING RADIATION DAMPER
CU	CONDENSING UNIT
DB	DRY BULB TEMPERATURE
DDC	DIRECT DIGITAL CONTROL
DSD	DUCT SMOKE DETECTOR
E	EXITING
EAT	ENTERING AIR TEMPERATURE
EBH	ELECTRIC BASEBOARD HEATER
EX	EXHAUST
FAI	FRESH AIR INTAKE
FC	FLEXIBLE CONNECTION
FCU	FAN COIL UNIT
FD	FIRE DAMPER
FL	FIRE LIFT
FL	FUSIBLE LINK REGISTER
FR	FLOOR REGISTER
FSD	COMBINATION FIRE/SMOKE DAMPER
FTR	FINNED TUBE RADIATION
HC	HEATING COIL
HX	HEAT EXCHANGER (CONVERTER)
JD(TD)	JUMP DUCT (TRANSFER DUCT)
KX	KITCHEN EXHAUST
LAT	LEAVING AIR TEMPERATURE
LWT	LEAVING WATER TEMPERATURE
M	MOTOR
MCC	MOTOR CONTROL CENTER
MER	MECHANICAL EQUIPMENT ROOM
MLWMS	METAL LOUVER WITH WIRE MESH SCREEN
MO	MASONRY OR WALL OPENING (1 SQ. FT U.O.N.)
N	NEW
NC	NORMALLY CLOSED
NIC	NOT IN CONTRACT
NK	NECK SIZE
NO	NORMALLY OPEN
NTS	NOT TO SCALE
OAI	OUTSIDE AIR INTAKE
OBD	OPPOSED BLADE DAMPER
P	PUMP
PC	PUMPED CONDENSATE
PHC	PRE HEAT COIL
R	RELOCATED
RA	RETURN AIR
RG	RETURN GRILLE
RR	REFRIGERANT RELIEF
R/S	RETURN/SPILL
S	SUPPLY
SA	SUPPLY AIR
SD	SMOKE DAMPER
SF	SQUARE FEET
SR	SIDE REGISTER
ST	SOUND TRAP
SX	SMOKE EXHAUST
S/S	STAINLESS STEEL
TD	TRANSFER DUCT
TF	TRANSFER FAN
TR(G)	TOP REGISTER OR GRILLE
TX	TOILET EXHAUST FAN
UAS	UNDER ANOTHER SECTION OF THE SPECIFICATION
UC	UNDERCUT DOOR (1 INCH)
UH	UNIT HEATER
UON	UNLESS OTHERWISE NOTED
VD	VOLUME DAMPER
VI	VIBRATION ISOLATOR
WB	WET BULB TEMPERATURE
WMS	WIRE MESH SCREEN

DUCTWORK SYMBOLS

	SUPPLY AIR DUCT UP
	EXHAUST OR RETURN AIR DUCT UP
	SUPPLY AIR DUCT DOWN
	EXHAUST OR RETURN AIR DUCT DOWN
	DUCT WITH ACOUSTIC LINING (1" THICK U.O.N.)
	FLEXIBLE DUCT
	CEILING DIFFUSER
	CEILING GRILLE (CEILING REGISTER WHERE NOTED AS CR)
	THERMOSTAT, SENSOR (DDC)
	DOOR LOUVER (SQ. FEET)
	UNDERCUT DOOR (1")
	CRD/FIRE DAMPER
	COMBINATION FIRE/SMOKE DAMPER (HORIZONTAL/VERTICAL)
	VOLUME DAMPER
	ACCESS DOOR
	ELECTRIC BASEBOARD HEATER
	WIRE MESH SCREEN
	WALL CAP
	AIR HANDLING UNIT
	COMBUSTION AIR HIGH/LOW GRILLES
	FLOOR SUPPLY REGISTER

KEY TO SYMBOLS

SYMBOL	DESCRIPTION
	EQUIPMENT IDENTITY (SEE EQUIPMENT ABBREVIATION LIST AND SCHEDULES) EQUIPMENT DESIGNATION SYSTEM NUMBER (IF APPLICABLE)
	RISER TYPE. REFER TO ABBREVIATIONS RISER DESIGNATION RISER NUMBER. REFER TO PLANS AND/OR RISER DIAGRAMS
	SECTION NUMBER SECTION DESIGNATION SECTION DRAWING NUMBER
	REVISION NUMBER
	SHEET NOTE NUMBER
	EQUIPMENT IDENTITY (SEE EQUIPMENT ABBREVIATION LIST AND SCHEDULES) EQUIPMENT TYPE EQUIPMENT SIZE EQUIPMENT CAPACITY



Paterson Habitat For Humanity
146 North 1st Street
Paterson, NJ 07522

PROJECT NAME

135 SUMMER STREET
PASSAIC, NJ

CHEN O'NEIL ARCHITECTS, PLLC

29 GANUNG DRIVE
OSSINING, NY 10562
646-812-5566

KEAO
ENGINEERS
Engineering Excellence since 1984
186 WOOD AVE. SOUTH 1ST FLOOR
ISSELIN, NJ 08830
TEL (732) 635 0044 • FAX (732) 635 1777

2	100% PERMIT SET	2/02/2021
1	80% DD SET	1/08/2021

ISSUE/REVISION DATE

DRAWING TITLE

MECHANICAL
COVER SHEET

DRAWING NO.

M-001

DATE: 12/01/20
SCALE: AS NOTED

STAMP & SIGNATURE



Paterson Habitat For Humanity
146 North 1st Street
Paterson, NJ 07522

PROJECT NAME

135 SUMMER STREET
PASSAIC, NJ

CHEN O'NEIL ARCHITECTS, PLLC

29 GANUNG DRIVE
OSSINING, NY 10562
646-812-5566



KEAO ENGINEERS
Engineering Excellence since 1984
186 WOOD AVE. SOUTH, 1ST FLOOR
ISSLUI, NJ 08850
TEL (732) 635 0044 • FAX (732) 635 1777

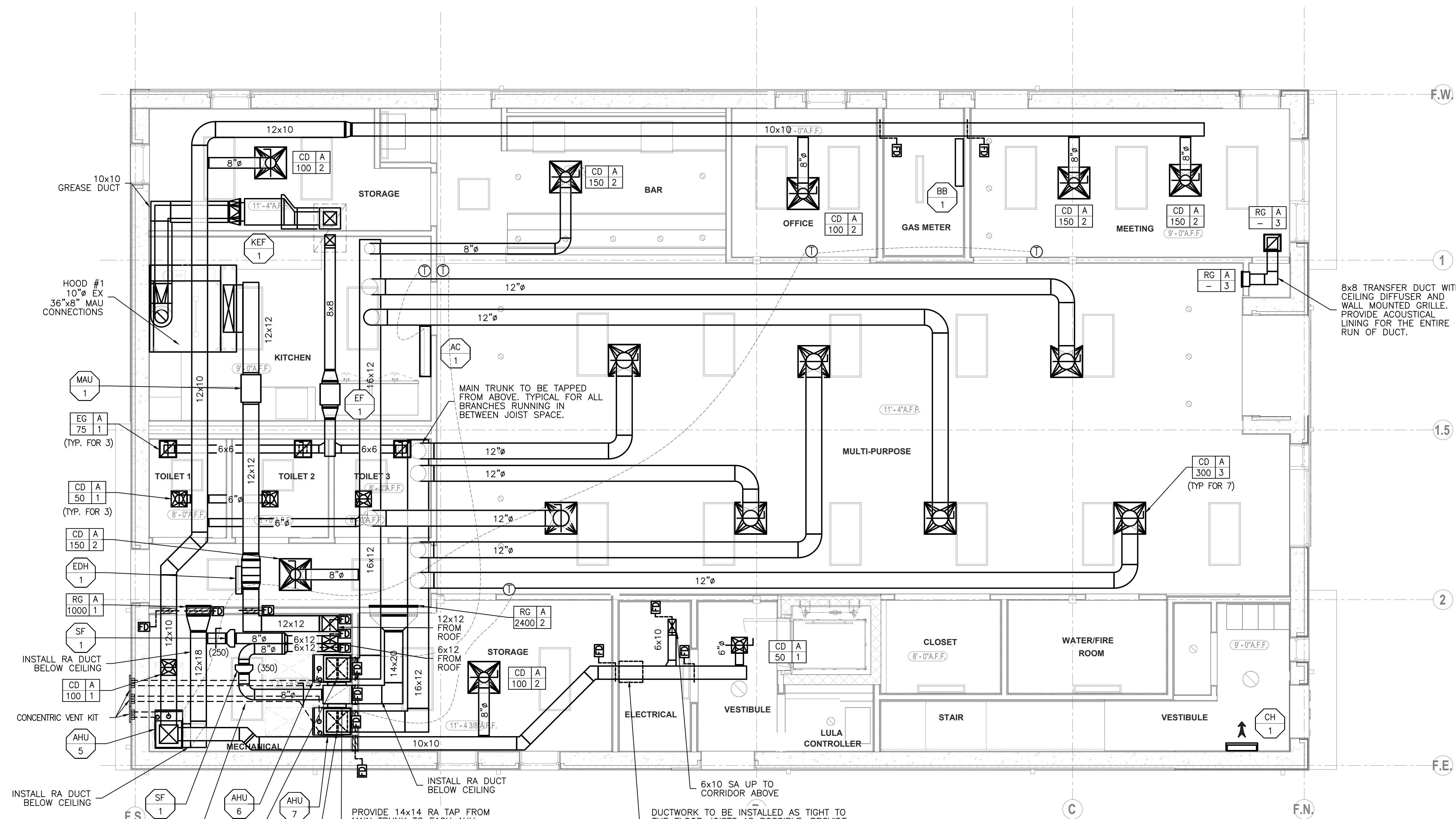

- MECHANICAL KEY NOTES:**
- FURNISH AND INSTALL AHU UNIT AS REQUIRED BY MANUFACTURER. PROVIDE REQUIRED CLEARANCE FOR SERVICE. PROVIDE SS DRIP PAN, RUN 3/4" CONDENSATE PIPING FROM THE COOLING COIL DOWN TO FUNNEL IN THE FLOOR DRAIN. REFER TO DETAILS FOR MORE INFORMATION. FLOOR DRAIN WILL BE PROVIDED (BY OTHERS) IN MECHANICAL ROOM.
 - RUN SUPPLY TRUNK ABOVE CEILING, BELOW TRUSSES. TAP MAIN TRUNK FROM ABOVE AND RUN BRANCHES INTO SPACE BETWEEN TRUSSES AND RUN ALONG TRUSS SPAN. PROVIDE FD/AD AT CEILING PENETRATION. COORDINATE BRANCH FINAL LOCATION OPEN WEB TRUSSES.
 - INSTALL BRANCH DUCTWORK SERVING MULTI-PURPOSE SPACE AS INDICATED TO PROVIDE ADEQUATE ZONING. NO DEVIATION WILL BE ALLOWED. CHANGES TO LAYOUT WILL HAVE TO BE APPROVED BY ENGINEER OF RECORD.
 - FURNISH AND INSTALL 7-DAY PROGRAMMABLE THERMOSTAT. CONFIRM INSTALLATION LOCATION WITH OWNER AND ARCHITECT PRIOR TO INSTALLATION. RUN CONTROL WIRING TO THE AHU UNIT.
 - PROVIDE TWO (2) PROGRAMMABLE THERMOSTAT AND SWITCH (TWO POSITION, DOUBLE POLE, DOUBLE THROW) TO CONTROL AHU-5. WIRE SWITCH TO EACH OF THE TWO ZONES. PUT SWITCH IN REQUIRED POSITION TO MANUALLY ACTIVATE/DEACTIVATE REDUNDANT THERMOSTAT.
 - PROVIDE 1" UNDERCUT FOR ALL TOILETS, STORAGE ROOMS AND OFFICE SPACES.
 - RETURN DUCTWORK TO BE INSTALLED HIGH, TIGHT BELOW CEILING. PROVIDE THE REQUIRED TRANSITIONS, GRILLES AND FIRE DAMPERS AS PER RATING OF WALLS.
 - PROVIDE KITCHEN HOOD AS PER CAPTIVEARE DRAWINGS. TYPE I HOOD EXHAUST DUCTWORK TO BE 12 GAUGE STEEL AND WELDED LIQUID-TIGHT. DUCTWORK TO BE PITCHED 1/4" PER 12" TOWARDS HOOD OR APPROVED GREASE RESERVOIR OR 1" PER 12" IF HORIZONTAL DUCT RUN EXCEEDS 75 FT. CLEANOUTS MUST BE PROVIDED AT EVERY CHANGE IN DIRECTION, AND WITHIN 3 FT OF THE EXHAUST FAN. EXHAUST DUCTWORK TO BE WRAPPED WITH 3M MODEL +615 FIRE WRAP FROM HOOD TO ROOF PENETRATION.
 - INSTALL AIR PURIFICATION SYSTEM AS PER MANUFACTURER'S INSTRUCTIONS.

- SEQUENCE OF OPERATIONS**
- SF-1 TO BE INTERLOCKED WITH AHU-5. WHEN AHU-5 RUNS SF-1 WILL TURN ON.
 - SF-2 TO BE INTERLOCKED WITH AHU-6,7. WHEN ANY OF THE TWO UNITS RUNS SF-2 WILL TURN ON.
 - AHU-5,6,7 AND AC-1 SHALL BE CONTROLLED BY THERMOSTAT FOR HEATING AND COOLING.
 - KEF-1 TO BE INTERLOCKED WITH MANUAL HOOD CONTROLS AND DUCT-MOUNTED HEAT SENSOR.
 - MAU-1 TO BE INTERLOCK WITH KEF-1 AND EDH-1. WHEN KEF-1 TURNS ON, MAU-1 WILL TURN ON, EDH-1 WILL MODULATE HEAT TO MAINTAIN 75F (ADJ.).
 - EF-1 TO BE INTERLOCKED WITH TIME-CLOCK. COORDINATE WITH EC AND ELECTRICAL DRAWINGS.
 - TWO THERMOSTATS CAPABLE OF CONTROLLING AHU-5 SHALL BE PROVIDED. ONE FOR OFFICE, SECOND FOR MEETING ROOM. THERMOSTATS SHALL HAVE POWER INTERRUPTED BY SWITCHES. SWITCHES SHALL ALLOW FOR CONTROL TO BE SWITCHED OVER FROM ONE THERMOSTAT TO THE OTHER, HAVING ONLY ONE THERMOSTAT CONTROL AHU-5 AT A TIME.

- MECHANICAL GENERAL NOTES:**
- PROVIDE CRD'S WITH AD'S IN ALL DUCTWORK PENETRATING FIRE RATED CEILING.
 - COORDINATE FINAL DIFFUSER/SUPPLY GRILLES LOCATIONS WITH LIGHTING LAYOUT.
 - ALL RETURN DUCTWORK WILL HAVE ACOUSTICAL LINING.
 - ALL DIFFUSERS/SUPPLY GRILLES TO BE EQUIPPED WITH MEANS OF BALANCING.
 - ALL ANNULAR SPACE RESULTING FROM DUCT/PIPE PENETRATIONS SHALL BE PROTECTED WITH MATERIALS THAT PREVENT THE PASSAGE OF FLAME AND HOT GASES AS PER ASTM E 119 OR UL263 AND THAT HAVE THE EQUIVALENT FIRE-RESISTANCE RATING OF THE CONSTRUCTION PENETRATED.

MECHANICAL FIRST FLOOR REFLECTED CEILING PLAN
SCALE: 1/4" = 1'-0"

2	100% PERMIT SET	2/02/2021
1	80% DD SET	1/08/2021

ISSUE/REVISION DATE

DRAWING TITLE
MECHANICAL FIRST FLOOR REFLECTED CEILING PLAN

DRAWING NO.
M-101

DATE: 12/01/20
SCALE: AS NOTED

STAMP & SIGNATURE



Paterson Habitat For Humanity
146 North 1st Street
Paterson, NJ 07522

PROJECT NAME

135 SUMMER STREET
PASSAIC, NJ

CHEN O'NEIL ARCHITECTS, PLLC

29 GANUNG DRIVE
OSSINING, NY 10562
646-812-5566



KEAO ENGINEERS
Engineering Excellence since 1984
186 WOOD AVE. SOUTH - 1ST FLOOR
ISSELIN, NJ 08830
TEL (732) 635 0044 • FAX (732) 635 1777

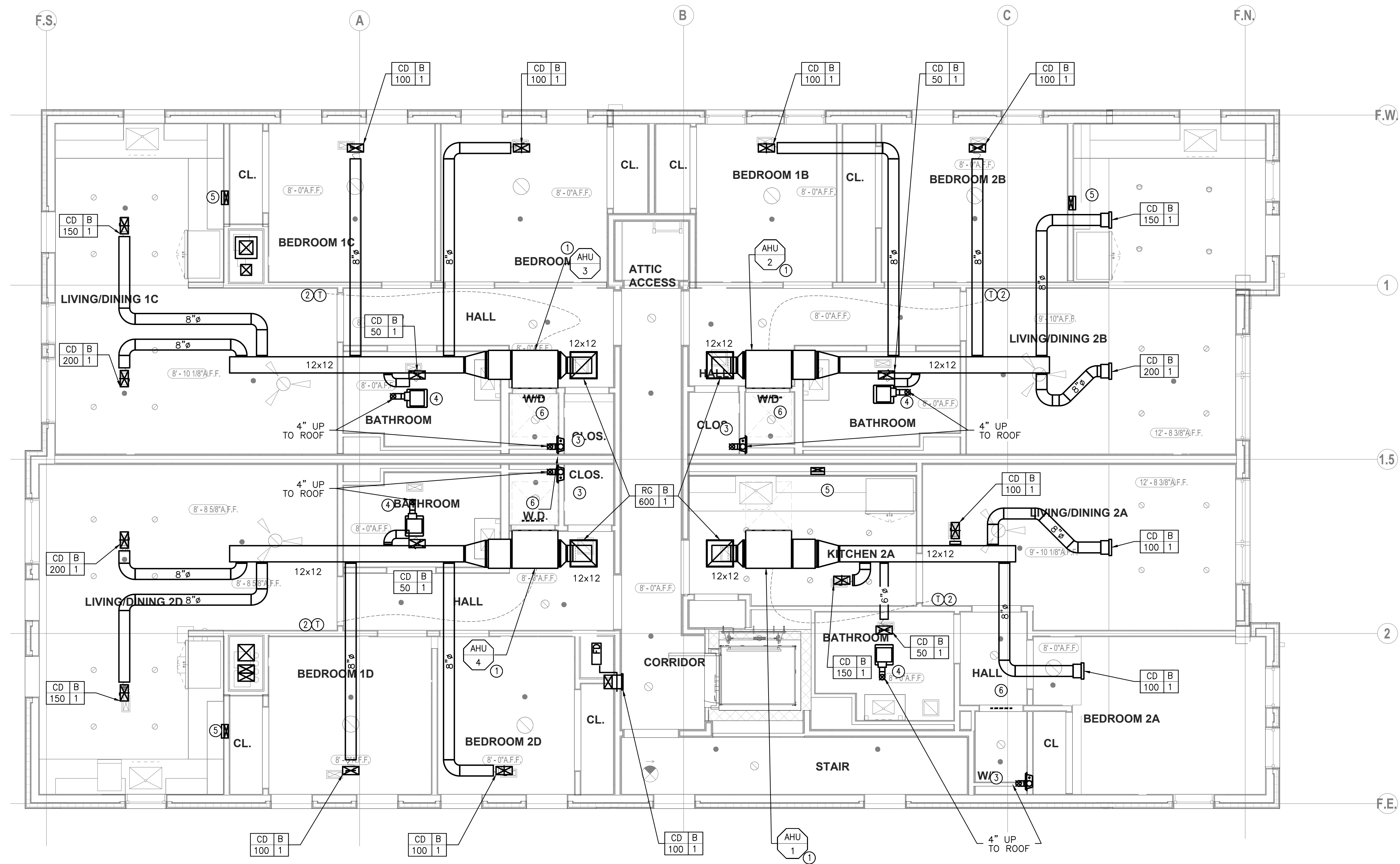

MECHANICAL SECOND FLOOR REFLECTED CEILING PLAN
SCALE: 1/4" = 1'-0"

MECHANICAL GENERAL NOTES:

- UNDERCUT RESTROOM AND BEDROOM DOORS 0.5", TYPICAL FOR ALL UNITS.
- PROVIDE CRD'S WITH AD'S IN ALL DUCTWORK PENETRATING FIRE RATED CEILING.
- COORDINATE FINAL DIFFUSER LOCATIONS WITH LIGHTING LAYOUT.
- ALL RETURN DUCTWORK WILL HAVE ACOUSTICAL LINING.
- ALL SUPPLY GRILLES TO BE EQUIPPED WITH MEANS OF BALANCING.

MECHANICAL KEY NOTES:

1. FURNISH AND INSTALL AHU UNIT AS REQUIRED BY MANUFACTURER. PROVIDE REQUIRED CLEARANCE FOR SERVICE. PROVIDE SS DRIP PAN WITH PAN OVERFLOW SENSOR INTERLOCKED WITH AHU. RUN 3/4" Ø CONDENSATE PIPING FROM THE COOLING COIL DOWN TO THE RESPECTIVE CLOTHES WASHER STAND PIPE.
2. FURNISH AND INSTALL THERMOSTAT. CONFIRM INSTALLATION LOCATION WITH OWNER AND ARCHITECT PRIOR TO INSTALLATION. RUN CONTROL WIRING TO THE AHU UNIT.
3. PROVIDE UL LISTED RECESSED DRYER VENT BOX IN-O-VATE TECHNOLOGIES, INC. MODEL 350 AND/OR 425 APPROVED FOR 2X4 AND/OR 2X6 STUD WALL INSTALLATION. RUN 4" Ø DRYER DUCT UP TO ROOF AND TERMINATE WITH GOOSENECK.
4. EXHAUST FAN TX-1 TO HAVE INTERNAL MOTION SENSOR. FAN TO RUN AT 50 CFM CONTINUOUSLY AND RAMP UP TO 75 UPON DETECTION OF OCCUPANTS. RUN 4" Ø DRYER DUCT UP TO ROOF AND TERMINATE WITH ROOF JACK.
5. PROVIDE MICROWAVE BACK VENT CONNECTION. RUN DUCT INSIDE WALL UP TO ATTIC. PROVIDE TRANSITION TO 6" GOING THROUGH THE ROOF AND TERMINATE WITH ROOF JACK.
6. PROVIDE TWO (2) 60 IN² FREE AREA (MIN.) GRILLE ON DOOR, ONE LOW, ONE HIGH. REFER TO WASHING MACHINE MANUFACTURER SPECIFICATIONS. COORDINATE GRILLE SIZE AND FINISH WITH ARCHITECT.

2	100% PERMIT SET	2/02/2021
1	80% DD SET	1/08/2021

ISSUE/REVISION DATE

DRAWING TITLE

MECHANICAL SECOND FLOOR REFLECTED CEILING PLAN

DRAWING NO.

M-102

DATE: 12/01/20

SCALE: AS NOTED

STAMP & SIGNATURE



Paterson Habitat For Humanity
146 North 1st Street
Paterson, NJ 07522

PROJECT NAME

135 SUMMER STREET
PASSAIC, NJ

CHEN O'NEIL ARCHITECTS, PLLC

29 GANUNG DRIVE
OSSINING, NY 10562
646-812-5566



186 WOOD AVE. SOUTH, 1ST FLOOR
ISELIN, NJ 08830
TEL (732) 635 0044 • FAX (732) 635 1777

2 100% PERMIT SET 2/02/2021

1 80% DD SET 1/08/2021

ISSUE/REVISION DATE

DRAWING TITLE

MECHANICAL
ROOF
CONSTRUCTION PLAN

DRAWING NO.

M-103

DATE: 12/01/20

SCALE: AS NOTED

STAMP & SIGNATURE

ARMEN KHACHATURIAN, P.E. - NJ LICENSE #21295
NJ CERTIFICATE OF AUTHORIZATION #246428034700

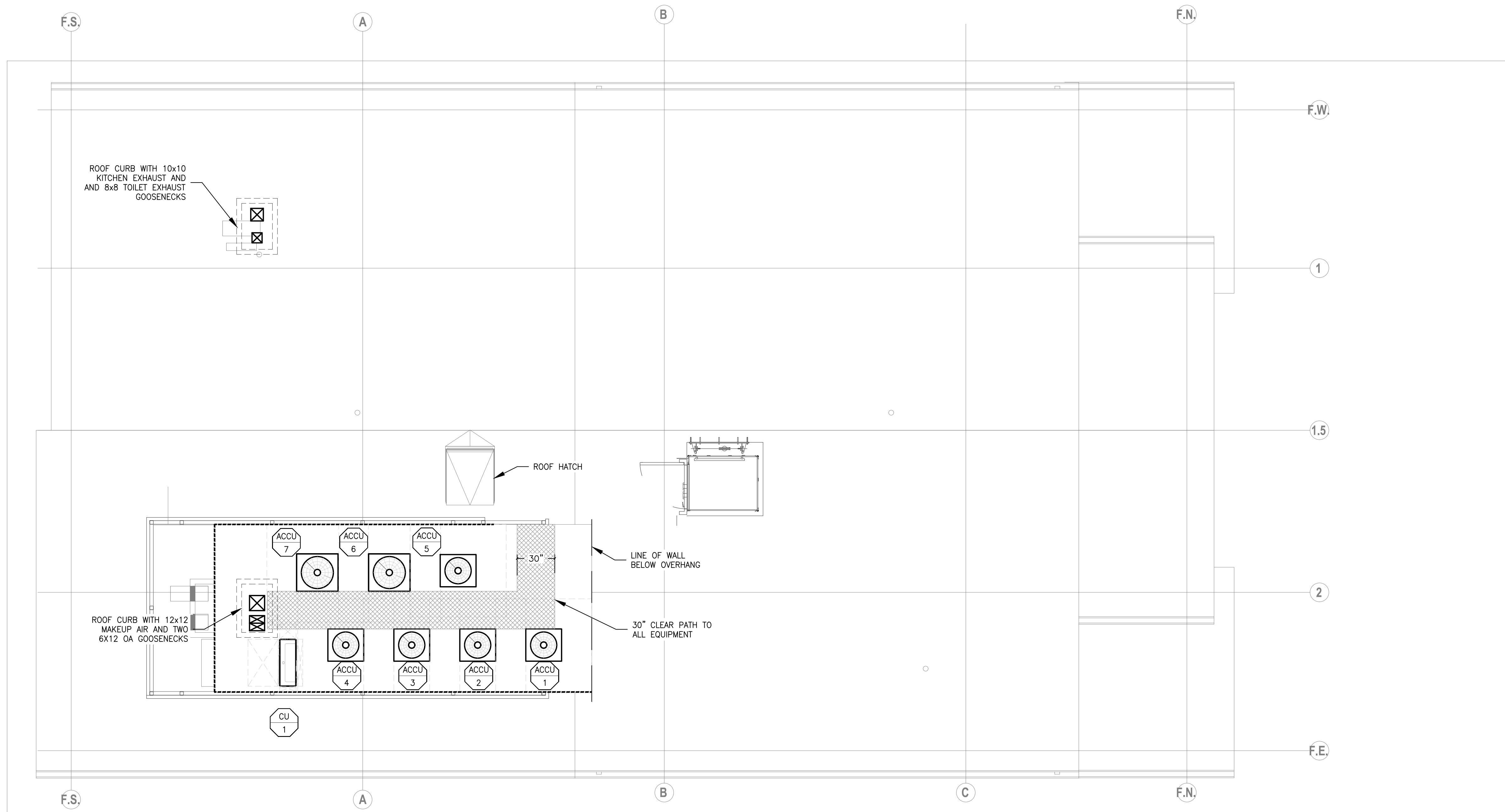

MECHANICAL ROOF CONSTRUCTION PLAN
SCALE: 1/4" = 1'-0"

MECHANICAL GENERAL NOTES:

- CONTRACTOR SHALL BE RESPONSIBLE FOR COORDINATING ALL WORK WITH OTHER TRADES.
- ALL NEW DUCTWORK LOCATED OUTDOORS SHALL BE PROTECTED WITH WEATHERPROOF PAINT.
- ALL GOOSENECK TERMINATIONS SHALL BE PROVIDED WITH WIRE MESH SCREEN.
- COORDINATE EXACT LOCATION OF ALL NEW MECHANICAL EQUIPMENT IN FIELD WITH OWNER AND ARCHITECT.
- CONTRACTOR SHALL VERIFY THAT ALL EQUIPMENT, AS SHOWN ON THESE DRAWINGS, WILL NOT CONFLICT WITH ANY DRAINS, JOINTS, VENTS, PIPING, EQUIPMENT, ETC.
- ALL REFRIGERANT PIPING SHALL BE INSTALLED FOLLOWING MANUFACTURE'S GUIDELINES. REFER TO MANUFACTURER RECOMMENDATION FOR PIPE SIZING, INSULATION, LENGTHS AND ACCESSORIES REQUIRED.

MECHANICAL KEY NOTES:

1. MAINTAIN ALL MANUFACTURER'S RECOMMENDED CLEARANCES.
2. PROVIDE 6" PLASTIC PADS AND INSTALL ACCU'S ON PLATFORM (BY OTHERS, REFER TO ARCHITECTURAL SET). SEALS ALL PENETRATIONS REQUIRED FOR REFRIGERANT PIPING, POWER AND CONTROL WIRING. COORDINATE INSTALLATION OF REFRIGERANT PIPING WITH MANUFACTURER'S RECOMMENDATIONS FOR NUMBER OF BENDS AND TOTAL LENGTH.
3. TOILET/KITCHEN EXHAUST TERMINATION SHALL BE KEPT 3 FT (VERTICAL) OR 10 FT (HORIZONTAL) AWAY FROM ANY OUTSIDE AIR INTAKE. VERTICALLY EXTEND RISERS AS REQUIRED TO MEET SEPARATION REQUIREMENTS.
4. PROVIDE WEATHER PROTECTION TO ALL DUCTWORK EXPOSED TO THE OUTSIDE. INSULATE WITH R-8 INSULATION ALL OUTSIDE AIR DUCTWORK.

1 SCOPE OF WORK

1.1. THE WORK UNDER THIS SECTION SHALL INCLUDE ALL LABOR, MATERIALS, EQUIPMENT, HOISTING, SCAFFOLDING, SUPPORT, SUPERVISION, SERVICES AND OPERATIONS NECESSARY TO COMPLETE THE INSTALLATION OF THE HEATING, VENTILATING AND AIR CONDITIONING WORK SHOWN IN ACCORDANCE WITH THE CONTRACT DOCUMENTS. THE SCOPE OF WORK SHALL INCLUDE BUT NOT BE LIMITED TO THE FOLLOWING.

2 GENERAL CONDITIONS - HVAC

2.1. THE GENERAL CONDITIONS AND THE SUPPLEMENTARY CONDITIONS OF THE CONTRACT FOR CONSTRUCTION AND THE ARCHITECTS AND ENGINEER'S SPECIFICATIONS AS APPLICABLE ARE PART OF THIS CONTRACT.

2.2. THE ENTIRE INSTALLATION SHALL CONFORM WITH THE MOST RECENTLY REVISED VERSION OF ALL APPLICABLE LAWS, RULES, REGULATIONS, CODES, ORDINANCES OF FEDERAL, STATE AND LOCAL AUTHORITIES HAVING JURISDICTION, INCLUDING, BUT NOT LIMITED TO, THE FOLLOWING: THE STATE ENERGY CONSERVATION CODE, IBC CODE, NATIONAL ELECTRIC CODE, INDUSTRIAL RISK INSURERS, ELECTRIC TESTING LABORATORY, ASHRAE, ASME, NFPA, AND UL.

2.3. REMOVAL AND DISPOSAL OF EXISTING EQUIPMENT AND CONSTRUCTION DEBRIS FROM THE SITE IS THE RESPONSIBILITY OF THIS CONTRACTOR, WITH THE EXCEPTION OF SPECIFIC EQUIPMENT AND APPARATUS WHICH MAY BE REQUIRED TO BE TURNED OVER TO THE OWNER/TENANT OR THE BUILDING REPRESENTATIVE.

2.4. ALL WORK AND MATERIALS SHALL BE GUARANTEED AS TO QUALITY AND WORKMANSHIP, AND GUARANTEED AGAINST ALL DEFECTS, FOR A PERIOD OF ONE YEAR.

2.5. PROVIDE ALL-RISK BUILDERS' INSURANCE IN ACCORDANCE WITH THE REQUIREMENTS OF THE BUILDING AND/OR THE OWNER, NAMING THE OWNER, ARCHITECT AND ENGINEER AS ADDITIONAL INSUREDS AND CONTAINING A PROVISION THAT THE INSURANCE IS NOT CANCELABLE UNTIL 30 DAYS AFTER THE CONTRACTOR, OWNER, ARCHITECT AND ENGINEER HAVE RECEIVED WRITTEN NOTICE OF INTENTION TO CANCEL. IN THE EVENT OF CANCELLATION, THE OWNER HAS THE OPTION TO REPLACE SUCH INSURANCE AT THE CONTRACTOR'S EXPENSE.

2.6. THE CONTRACTOR AND SUBCONTRACTORS, IF ANY, COVENANT AND AGREE:

2.6.1. TO INDEMNIFY, DEFEND AND HOLD HARMLESS THE OWNER, ARCHITECT AND CONSULTING ENGINEERS AGAINST ANY LIABILITY, LOSS, DAMAGE OR EXPENSE, INCLUDING ATTORNEYS' FEES, ARISING FROM A FAILURE OR ALLEGED FAILURE ON THE PART OF THE CONTRACTOR, HIS SUBCONTRACTORS OR HIS OR THEIR AGENTS, SERVANTS AND EMPLOYEES PROPERLY TO DISCHARGE THE OBLIGATIONS ASSUMED BY HIM OR THEM IN PERFORMANCE OF THE WORK, INCLUDING ANY ACT OR OMISSION ALLEGEDLY RESULTING IN DEATH OR PERSONAL INJURY OR PROPERTY DAMAGE OR IMPROPER CONSTRUCTION, CONSTRUCTION TECHNIQUES, OR THE USE OF IMPROPER OR INAPPROPRIATE MATERIALS, METHODS OR TOOLS.

2.6.2. TO EXECUTE THE WORK IN THE BEST AND MOST THOROUGH MANNER AND TO THE SATISFACTION OF THE OWNER, ARCHITECT AND CONSULTING ENGINEERS, WHO WILL JOINTLY INTERPRET THE MEANING OF THE DRAWINGS AND SPECIFICATIONS AND SHALL HAVE THE POWER TO REJECT ANY WORK AND MATERIALS WHICH, IN THEIR JUDGMENT, ARE NOT IN FULL ACCORDANCE THEREWITH.

2.6.3. TO BE RESPONSIBLE FOR ALL MATERIAL UNTIL COMPLETION AND FINAL ACCEPTANCE. REPLACE ANY MATERIAL AND/OR EQUIPMENT WHICH MAY BE DAMAGED, LOST OR STOLEN AND TO DO OVER ANY REJECTED WORK WITHOUT ADDITIONAL COST TO THE OWNER. GUARD THE BUILDING AND ITS CONTENTS AGAINST DAMAGE BY THE CONTRACTOR OR HIS EMPLOYEES, AND MAKE GOOD ANY DAMAGE FREE OF CHARGE.

2.6.4. THAT HE WILL PROVIDE AND MAINTAIN A SAFE PLACE TO WORK AND THAT HE WILL COMPLY WITH ALL LAWS AND REGULATIONS OF ANY GOVERNMENTAL AUTHORITY HAVING JURISDICTION THEREOF, AND THAT HE AGREES TO INDEMNIFY, DEFEND AND HOLD HARMLESS THE OWNER, ARCHITECT AND CONSULTING ENGINEERS FROM AND AGAINST ANY LIABILITY, LOSS, DAMAGE OR EXPENSE, INCLUDING ATTORNEY'S FEES, ARISING FROM A FAILURE OR ALLEGED FAILURE ON HIS PART PROPERLY TO DISCHARGE THE OBLIGATIONS ASSUMED BY HIM OR THEM IN THE PERFORMANCE OF THE WORK, INCLUDING ANY ACT, ERROR OR OMISSION ALLEGEDLY RESULTING IN THE DEATH OR PERSONAL INJURY OR PROPERTY DAMAGE OR IMPROPER CONSTRUCTION, CONSTRUCTION TECHNIQUES, OR THE USE OF IMPROPER OR INAPPROPRIATE MATERIAL OR TOOLS.

2.6.5. THAT ANY CONTROVERSY OR DISPUTE TO WHICH THE CONTRACTOR, OWNER, ARCHITECT OR CONSULTING ENGINEERS ARE PARTIES SHALL BE SUBMITTED TO ARBITRATION BEFORE THE AMERICAN ARBITRATION ASSOCIATION FOR DECISION IN ACCORDANCE WITH THE RULES OF SUCH ASSOCIATION FOR CONSTRUCTION INDUSTRY DISPUTES. THE CONTRACTOR AGREES TO MAKE AVAILABLE TO THE CONSULTING ENGINEERS, ON DEMAND, SIGNED COPIES OF THE CONTRACT BETWEEN THE OWNER AND THE CONTRACTOR AND BETWEEN THE CONTRACTOR AND HIS SUBCONTRACTORS. THE CONTRACTOR AGREES THAT BY SUBMITTING A BID WHICH IS ACCEPTED, THIS PARAGRAPH SHALL BE DEEMED A WRITTEN AGREEMENT TO SUBMIT TO ARBITRATION ANY CONTROVERSY THEREAFTER ARISING.

2.6.6. PUT WORK IN PLACE AS FAST AS REASONABLY POSSIBLE; AT ALL TIMES, KEEP A COMPETENT FOREMAN IN CHARGE OF THE WORK AND FACILITATE ITS INSPECTION BY THE CONTRACTOR, ARCHITECT AND CONSULTING ENGINEERS.

2.6.7. EXCEPT FOR SUCH CHANGES AS MAY BE SPECIFICALLY APPROVED BY THE OWNER, ARCHITECT AND CONSULTING ENGINEERS, IN ACCORDANCE WITH ALTERNATES OR OPTIONS STATED HEREAFER, ALL WORK MUST BE IN FULL ACCORDANCE WITH THE PLANS AND SPECIFICATIONS, COMPLETE IN EVERY WAY FOR EFFICIENT AND SATISFACTORY OPERATION WHEN DELIVERED TO THE OWNER.

2.6.8. THAT THE MATERIALS WILL BE NEW AND THE WORKMANSHIP SUPPLIED UNDER THESE SPECIFICATIONS WILL BE OF THE BEST GRADE, THE APPARATUS WILL BE ERRECTED IN A PRACTICAL AND FIRST CLASS MANNER, IT WILL BE COMPLETE AND READY FOR OPERATION, NOTHING OMITTED IN THE WAY OF LABOR AND MATERIAL REQUIRED TO MAKE IT SO, ALTHOUGH NOT SPECIFICALLY SHOWN IN DETAIL OR MENTIONED HEREIN, AND THAT IT WILL BE DELIVERED IN GOOD WORKING ORDER, COMPLETE AND PERFECT IN EVERY RESPECT WITHOUT ADDITIONAL COST.

2.6.9. THAT SUBMISSION OF A BID IS A REPRESENTATION THAT THEY HAVE BECOME THOROUGHLY ACQUAINTED WITH THE WORK INVOLVED AND HAVE OBTAINED AND VERIFIED AT THE BUILDING ALL MEASUREMENTS NECESSARY FOR THE PROPER INSTALLATION OF WORK. FURNISH TO ALL SECTIONS ANY INFORMATION RELATING TO WORK OF THIS SECTION NECESSARY FOR THE PROPER INSTALLATION OF THEIR SECTIONS. THE CONTRACTOR SHALL COORDINATE FOR FINISHES ADJACENT TO WORK OF THIS SECTION AND TO ARRANGE TO HAVE VISIBLE PORTIONS OF WORK FIT IN AND HARMONIZE WITH THE FINISH IN A MANNER SATISFACTORY TO THE ARCHITECT.

2.6.10. TO MAKE EVERY EFFORT TO FURNISH ALL EQUIPMENT OF ANY GENERIC TYPE FROM ONE MANUFACTURER.

2.6.11. WHERE INCONSISTENCIES OCCUR BETWEEN THE PLANS AND SPECIFICATIONS, OR WITHIN EITHER DOCUMENT ITSELF, THE ITEM OR ARRANGEMENT OF BETTER QUALITY, GREATER QUANTITY OR HIGHER COST HAS BEEN INCLUDED IN THE BASE BID.

2.7. DELIVERY AND STORAGE OF MATERIALS SHALL BE PERFORMED AS DIRECTED BY THE TENANT REPRESENTATIVE AND COORDINATED WITH THE BUILDING OWNER'S REPRESENTATIVE.

2.8. ALL WORK SHALL COMPLY WITH BUILDING RULES AND REGULATIONS GOVERNING TENANT ALTERATIONS.

2.9. THE CONTRACTOR SHALL PREPARE AND SUBMIT ALL APPLICATIONS TO AUTHORITIES AND OBTAIN ALL NECESSARY BUILDING PERMITS, EQUIPMENT USE PERMITS, COMPLETE ALL TESTS AND PAY ALL NECESSARY FEES.

2.10. THE CONTRACTOR SHALL PROTECT ALL EXISTING SURFACES, UTILITIES, MECHANICAL SYSTEMS, ETC., AND REPAIR ALL DAMAGES TO SAME DURING THE COURSE OF THIS CONTRACTOR'S WORK, AT HIS EXPENSE.

2.11. THE WORK SHALL BE PERFORMED IN PHASES IN ACCORDANCE WITH THE TENANTS, ARCHITECTS AND/OR ENGINEER'S SCHEDULE. ANY REQUIRED SHUTDOWN OF EXISTING EQUIPMENT OR SERVICES WHICH NEW EQUIPMENT SERVES AND/OR IS CONNECTED THERETO MUST BE SCHEDULED THROUGH THE BUILDING OWNER'S REPRESENTATIVE.

2.12. SUBMIT SHEET METAL SHOP STANDARDS, EQUIPMENT CUTS, DETAILED COORDINATED SHOP DRAWINGS OF ALL PIPING AND DUCT LAYOUTS FOR APPROVAL. PREPARE AND SUBMIT DRAWINGS SHOWING THE METHOD OF SUPPORT AND WEIGHT OF ALL EQUIPMENT, PIPING AND DUCTWORK FOR REVIEW BY THE ARCHITECT, ENGINEER AND BUILDING STRUCTURAL ENGI- NEER. PROMPTLY REVISE SHOP DRAWINGS AS REQUIRED BY THE OWNER, ARCHITECT OR ENGINEER AND RESUBMIT FOR FINAL APPROVAL. NO WORK SHALL START UNTIL EQUIPMENT CUTS, SHOP STANDARDS AND SHOP DRAWINGS ARE SUBMITTED AND APPROVED BY ARCHITECT AND/OR ENGINEER. COORDINATED DRAWINGS SHALL INCLUDE ALL MECHANICAL, ELECTRICAL, PLUMBING, FIRE PROTECTION AND GENERAL CONSTRUCTION DRAWINGS.

2.13. THE ARCHITECT AND/OR ENGINEER WILL REVIEW SHOP DRAWINGS AND/OR SAMPLES WITH REASONABLE PROMPTNESS AND WILL RETURN THEM TO THE CONTRACTOR STAMPED TO INDICATE THE APPROPRIATE ACTION AS FOLLOWS:

2.13.1. "NO EXCEPTION TAKEN" MEANS THAT FABRICATION, MANUFACTURE OR CONSTRUCTION MAY PROCEED PROVIDING THE SUBMITTAL COMPLIES WITH THE CONTRACT DOCUMENTS.

2.13.2. "MAKE CORRECTIONS NOTED" MEANS THAT FABRICATION, MANUFACTURE OR CONSTRUCTION MAY PROCEED PROVIDING THE SUBMITTAL COMPLIES WITH THE ARCHITECT'S AND/OR ENGINEERS NOTATIONS AND THE CONTRACT DOCUMENTS. A COPY OF THE CORRECTED SUBMITTAL MUST BE RETURNED TO THE ARCHITECT AND/OR ENGINEER FOR RECORD. IF, FOR ANY REASON, THE CONTRACTOR CANNOT COMPLY WITH THE NOTATIONS, THE CONTRACTOR MUST RESUBMIT AS DESCRIBED FOR SUBMITTALS STAMPED "REVISE AND RESUBMIT"

2.13.3. "REVISE AND RESUBMIT" MEANS THAT THE CONTRACTOR MUST COMPLY WITH THE ARCHITECT'S AND/OR ENGINEER'S NOTATIONS AND RESUBMIT BEFORE FABRICATION, MANUFACTURE OR CONSTRUCTION MAY PROCEED SUBMITTALS STAMPED IN THIS MANNER ARE NOT PERMITTED ON THE PROJECT SITE.

2.13.4. "REJECTED" MEANS THAT THE SUBMITTAL DOES NOT COMPLY WITH THE CONTRACT DOCUMENTS AND THAT FABRICATION, MANUFACTURE OR CONSTRUCTION SHALL NOT PROCEED. SUBMITTALS STAMPED IN THIS MANNER ARE NOT PERMITTED ON THE PROJECT SITE.

2.14. FIRE DAMPERS SHALL BE DYNAMIC TYPE, RATED TO CLOSE AGAINST AIR FLOW WITH A MINIMUM 6.0 INCHES W.G. PRESSURE DIFFERENTIAL ACROSS THE CLOSED DAMPER, UL LISTED AND BE APPROVED FOR USE AND BEAR THE LABEL OF THE LOCAL GOVERNING AGENCY WHERE REQUIRED.

2.15. REFER TO ARCHITECT'S DRAWINGS FOR LOCATION OF FIRE-RATED PARTITIONS. INSTALL FIRE DAMPERS WITH ACCESS DOORS IN ALL EXISTING AND NEW DUCTWORK, ALL RETURN AIR OPENINGS AND/OR MASONRY OPENINGS WHICH CROSS FIRE- RATED PARTITIONS.

2.16. FIRE DAMPERS MUST BE INSTALLED IN ACCORDANCE WITH UL555 AND MANUFACTURER'S INSTRUCTIONS. EXISTING FIRE DAMPERS MUST BE PROVIDED WITH ANGLE IRON FRAMES WHERE REQUIRED.

2.17. ALL NEW AND EXISTING FULL-HEIGHT PARTITIONS (I.E., TO UNDERSIDE OF SLAB ABOVE) EXCEPT ROOMS WHERE HUMIDIFICATION OR INTEGRITY OF SOUNDPROOFING IS REQUIRED, SHALL BE PROVIDED WITH A TRANSFER OPENING IN WALL ABOVE CEILING. MECHANICAL CONTRACTOR TO CO- ORDINATE THIS REQUIREMENT WITH THE CONSTRUCTION MANAGER/GENERAL CONTRACTOR. TRANSFER OPENINGS (T.O.) SHALL BE SIZED FOR A VELOCITY OF 400 FT./MIN. AND PROVIDED WITH FIRE DAMPERS UNLESS OTHERWISE NOTED.

2.18. REMOVABLE ACCESS TILES OR ACCESS DOORS ARE REQUIRED IN HUNG CEILING FOR VOLUME DAMPERS, FIRE DAMPERS, AUTOMATIC LOUVER DAMPERS, SMOKE DETECTORS, VALVES, AND ALL OTHER MECHANICAL EQUIPMENT WHICH REQUIRES SERVICE. FURNISH ACCESS LOCATION REQUIREMENTS TO CONSTRUCTION MANAGER/GENERAL CONTRACTOR.

2.19. PREPARE AND FURNISH TO THE OWNER "AS-BUILT" DRAWINGS UTILIZING THE LATEST VERSION OF AUTOCAD EMPLOYING THE BUILDING OWNER'S LAYERING SYSTEM FOR ALL WORK INSTALLED. PROVIDE OPERATING AND MAINTENANCE MANUALS (5 COPIES), INCLUDING WIRING DIAGRAMS, LUBRICATION CHARTS AND RECOMMENDED PREVENTATIVE MAINTENANCE PROCEDURES, FOR EACH SYSTEM OR PIECE OF EQUIPMENT.

3 GRILLES, REGISTERS, DIFFUSERS

3.1. CEILING DIFFUSERS, RETURN GRILLES AND REGISTERS SHALL BE SIZED IN ACCORDANCE WITH THE TABLES ON THE DRAWING. SUPPLY REGISTERS SHALL BE FURNISHED WITH O.B.D.'S AND PATTERN CONTROLLERS. RETURN REGISTERS SHALL BE PROVIDED WITH O.B.D.'S. FRAME AND BORDER TYPES ARE TO BE COMPATIBLE WITH CEILING CONSTRUCTION. THE COLOR OF ALL AIR DEVICES IS SUBJECT TO THE TENANTS APPROVAL. PROVIDE BLANK- OFF BAFFLES IN CEILING DIFFUSERS AS SHOWN ON DRAWINGS. FOR EXACT LOCATIONS OF DIFFUSERS, GRILLES AND REGISTERS, REFER TO ARCHITECTURAL DRAWINGS.

3.2. AIR DISTRIBUTION DEVICES (DIFFUSERS, REGISTERS, LINEARS, AIR SLOTS, ETC.) INSTALLED IN INACCESSIBLE CEILINGS SHALL BE PROVIDED WITH REMOTE DUCT MOUNTED OBD'S OPERABLE THROUGH THE FACE OF THE AIR DISTRIBUTION DEVICE.

3.3. AS PART OF THIS WORK, ALL AIR OUTLETS SHOWN ON DESIGN DRAWINGS SHALL BE BALANCED BY AN INDEPENDENT BALANCER. SUBMIT BALANCING REPORTS FOR APPROVAL TO ARCHITECT AND ENGINEER.

4 SHEETMETAL AND DUCTWORK

4.1. DUCT LAYOUT SHOWN IS A SCHEMATIC REPRESENTATION OF DESIGN INTENT. NO ADDED COMPENSATION SHALL BE PERMITTED FOR VARIATIONS DUE TO FIELD CONDITIONS. COORDINATION WITH BOTH NEW AND EXISTING SERVICES, INCLUDING THOSE OF OTHER MECHANICALS, IS REQUIRED. ANY MAJOR VARIANCES OR DISCREPANCIES ARE TO BE INDICATED ON THE SHOP DRAWINGS AND REPORTED TO THE ARCHITECT AND/OR ENGINEER.

4.2. SHEET METAL DUCT AND PLENUM CONSTRUCTION SHALL BE IN ACCORDANCE WITH THE APPLICABLE SECTIONS OF SMACNA, "HVAC DUCT CONSTRUCTION STANDARDS, METAL AND FLEXIBLE" LATEST EDITION, WITH THE EXCEPTIONS HEREIN NOTED.

4.3. SHOP STANDARDS FOR SHEET METAL AND DUCT CONSTRUCTION MUST BE SUBMITTED AND APPROVED PRIOR TO FABRICATION.

4.4. NEW SUPPLY DUCTWORK FROM A/C UNIT AND DUCTWORK UPSTREAM OF VAV BOXES SHALL BE CONSTRUCTED AND INSTALLED IN ACCORDANCE WITH TABLE 1-5 FOR 2 INCH STATIC PRESSURE, EXCEPT THAT ALL LONGITUDINAL SEAMS, TAPS AND TRANSVERSE JOINTS SHALL BE SEALED CLASS "A"

4.5. TOILET EXHAUST DUCTS SHALL BE CLASS "A" SEALED.

4.6. ALL BRANCH DUCTWORK (SUPPLY AND RETURN) SHALL BE PROVIDED WITH VOLUME CONTROL DAMPERS. VOLUME CONTROL DAMPERS SHALL BE OF THE QUADRANT TYPE CONSTRUCTED IN ACCORDANCE WITH FIGURES 2-12 AND 2-13 OF THE SMACNA STANDARDS.

4.7. WHEREVER REINFORCING IS REQUIRED ON 2 SIDES, THE ENDS OF THE REINFORCING MUST BE CONNECTED TOGETHER BY MEANS OF RODS OR ANGLES AS SHOWN IN FIGURE 1-11 OF THE SMACNA STANDARDS.

4.8. THE USE OF BUTTON PUNCH, SNAP-LOCK (L-2), STANDING SEAM (L-4) AND SINGLE CORNER SEAM (L0-5) LONGITUDINAL SEAMS IS PROHIBITED.

4.9. THE FOLLOWING TRANSVERSE JOINTS ARE NOT PERMITTED: LAP (T-4), REINFORCED S SLIP (T-7), STANDING SEAMS (T-15 AND T-16), POCKET LOCK (T-17, T-18 AND T-19) AND CAPPED FLANGE (T-20).

4.10. WHERE MANUFACTURED TRANSVERSE JOINTS ARE USED (SMACNA T-25A, T- 25B, I.E. DUCT MATE, TDC, TDF ETC.), THEY SHALL BE SUBMITTED WITH AND INSTALLED IN ACCORDANCE WITH THE MANUFACTURER'S STANDARDS FOR CONSTRUCTION AND INSTALLATION.

4.11. EXHAUST DUCTS FROM WET AREAS SUCH AS DISHWASHERS, DRYERS OR SHOWER AREAS SHALL BE MADE OF MINIMUM 20 GAUGE TYPE 304 STAINLESS STEEL HAVING PAN TYPE CONSTRUCTION AND CONTINUOUSLY WELDED TRANSVERSE JOINTS.

4.12. KITCHEN EXHAUST DUCTS SHALL BE CARBON STEEL WITH CONTINUOUSLY WELDED LONGITUDINAL SEAMS AND TRANSVERSE JOINTS. ALL BRANCH DUCT CONNECTIONS SHALL ALSO BE WELDED. THE ENTIRE INSTALLATION SHALL BE IN ACCORDANCE WITH THE REQUIREMENTS OF THE INTERNATIONAL MECHANICAL CODE. DUCT GAUGES SHALL BE CONSTRUCTED OF STEEL NOT LESS THAN 0.055 INCH (NO. 16 GAUGE) IN THICKNESS.

4.13. RAISED ACCESS DOORS SHALL BE PROVIDED 20 FEET ON CENTERS AND AT ALL CHANGES IN DIRECTION. ACCESS DOORS SHALL BE 18 BY 18 INCHES MINIMUM EXCEPT WHERE LIMITED BY DUCT DIMENSIONS, IN SUCH CASES THE OPENING SHALL BE LARGE ENOUGH TO PERMIT CLEANING HOWEVER THE MINIMUM HORIZONTAL DIMENSION SHALL BE 18 INCHES. ACCESS DOORS SHALL BE LOCATED A MINIMUM OF 1-1/2 INCHES ABOVE THE BOTTOM OF THE DUCT. DOORS SHALL BE MANUFACTURED BY DUCTMATE MODEL NO. DW1818ULWMS AS STANDARD.

4.13. KITCHEN EXHAUST DUCTS SHALL PITCH UPWARD IN THE DIRECTION OF AIR FLOW IN ACCORDANCE WITH THE REQUIREMENTS OF ALL GOVERNING CODES.

5 INSULATION AND ACOUSTIC TREATMENT

5.1. THERMAL AND ACOUSTICAL INSULATION AND ACCESSORY MATERIALS SHALL BE LISTED AND LABELED BY UNDERWRITERS LABORATORIES, INC., FOR A FIRE HAZARD CLASSIFICATION NOT TO EXCEED THE FOLLOWING: FLAME SPREAD, 25; FUEL CONTRIBUTION, 50; SMOKE DEVELOPED, 50, AS TESTED UNDER ASTM E-84, NFPA 255 OR UL 723 PROCEDURES.

5.2. WHERE INDICATED, DUCTWORK SHALL BE ACOUSTICALLY LINED WITH 1 INCH THICK, 1-1/2 POUND DENSITY, MATTE-FACE DUCT-LINER FORMULATED WITH AN IMMOBILIZED EPA REGISTERED ANTI-MICROBIAL AGENT. DIMENSIONS OF LINED DUCTS ARE CLEAR INSIDE WITH LINING INSTALLED. DUCT LINER SHALL BE ADHERED BY A FIRE RETARDANT ADHESIVE. MECHANICAL FASTENERS SUCH AS GRIP NAILS, WHICH DO NOT PIERCE THE SHEET METAL SHALL BE INSTALLED ON 16 INCH CENTERS ON TOP SECTIONS (WHEN WIDTH EXCEEDS 16 INCHES), AND ON SIDES (WHEN HEIGHT EXCEEDS 24 INCHES). ALL ABUTTING EDGES OF ACOUSTIC LINING SHALL BE CAULKED, AND EXPOSED EDGES OF ACOUSTIC LINING SHALL BE PROVIDED WITH SHEET METAL NOSINGS.

5.3. ALL RECTANGULAR SUPPLY DUCTWORK WITHIN 15 FEET AND RETURN DUCTWORK WITHIN 10 FEET OF THE HVAC UNIT SHALL BE INTERNALLY LINED. INTERNAL LINING SHALL BE 1 INCH THICK, 1-1/2 LB DENSITY LINER. LINER SHALL HAVE A COATED SURFACE EXPOSED TO AIRSTREAM TO PREVENT EROSION. APPLY ADHESIVES AND MECHANICAL FASTENERS AS RECOMMENDED BY SMACNA AND THE MANUFACTURER TO PREVENT LINER SEPARATION FROM THE DUCT. ALL TRANSVERSE EDGES SHALL BE COATED WITH ADHESIVE.

5.4. NEW AND EXISTING SUPPLY AND RETURN DUCTWORK SHALL BE INSULATED WITH A MINIMUM R-8 INCH THICK, 3/4 POUND DENSITY FIBER GLASS BLANKET WITH FACTORY-APPLIED SCRIM REINFORCED, FOIL FACED VAPOR BARRIER (FSK) WITH 2 INCH FLANGE. WRAP INSULATION TIGHTLY ON DUCT AND FIRMLY BUTT ALL JOINTS WITH 2 INCH FLANGE OVERLAP AT ALL SEAMS., ADHERE TO DUCT WITH 2/3 COVERAGE OF ADHESIVE APPLIED 4 INCH WIDE BANDS, 8 INCHES ON CENTERS. SEAL ALL JOINTS AND SEAMS WITH MINIMUM 3 INCH WIDE FSK TAPE. SUPPORT INSULATION ON THE BOTTOM OF RECTANGULAR DUCTS OVER 36 INCHES WIDE WITH A SINGLE ROW OF WELD PINS AND SPEED WASHERS. WIRE WRAPPING IS NOT PERMITTED. CUT WELD PINS OFF FLUSH WITH TOP OF SPEED WASHERS AND COVER WITH FSK TAPE TO MAINTAIN VAPOR BARRIER. WHERE ACOUSTICAL LINING IS INDICATED, NO THERMAL INSULATION IS REQUIRED.

6 CLEANING, TESTING AND ADJUSTING

6.1. DURING CONSTRUCTION, PROPERLY PROTECT ALL OPEN ENDS OF DUCTWORK TO PREVENT THE ENTRANCE OF SAND, DIRT AND OTHER FOREIGN MATTER IN ACCORDANCE WITH SMACNA STANDARDS.

6.2. ALL VAV BOXES, FANS, REGISTERS AND DIFFUSERS ARE TO BE BALANCED WITHIN PLUS 10%, MINUS 5% OF THE QUANTITIES SHOWN ON THE PLANS. BALANCING IS TO BE PERFORMED BY AN INDEPENDENT BALANCING AGENCY IN ACCORDANCE WITH A.A.B.C. OR N.A.A.B. NATIONAL STANDARDS.

7 CONTROLS

7.1. ALL CONTROL DEVICES, PNEUMATIC TUBING, AUTOMATIC DAMPERS, VALVES, THERMOSTATS, POWER AND CONTROL WIRING, CONDUIT AND WIRING FOR INTERLOCKS, START/STOPS, POWER WIRING OF CONTROL DEVICES AND PANELS, AND INTERCONNECTION OF ALL SAFETIES, ETC., FOR ALL HVAC EQUIPMENT SHALL BE PROVIDED AND INSTALLED BY THIS CONTRACTOR. SUBMIT DETAILED SHOP DRAWINGS AND CUTS OF ALL CONTROL EQUIPMENT AS WELL AS A SEQUENCE OF OPERATION FOR APPROVAL BY ENGINEER.



Paterson Habitat For Humanity
146 North 1st Street
Paterson, NJ 07522

PROJECT NAME

**135 SUMMER STREET
PASSAIC, NJ**



29 GANUNG DRIVE
OSSINING, NY 10562
646-812-5566



186 WOOD AVE. SOUTH, 1ST FLOOR
ESSLIE, NJ 08830
TEL (732) 635 0044 • FAX (732) 635 1777

2	100% PERMIT SET	2/02/2021
1	80% DD SET	1/08/2021

ISSUE/REVISION	DATE
-----------------------	-------------

DRAWING TITLE

**MECHANICAL
SPECIFICATIONS**

DRAWING NO.

M-301

DATE:	12/01/20
SCALE:	AS NOTED

STAMP & SIGNATURE

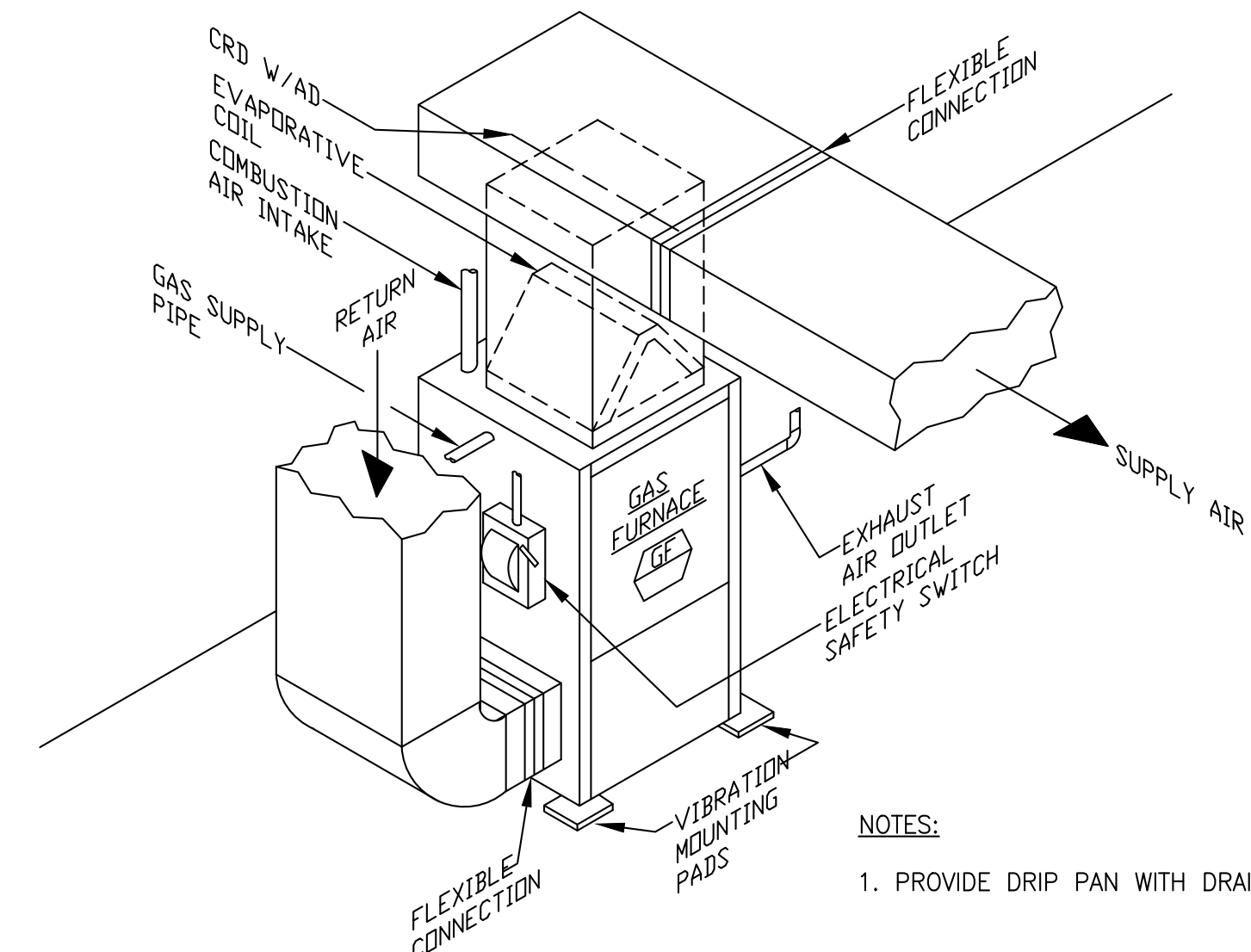

**UPFLOW GAS FURNACE DETAIL
DESCRIPTION DETAIL**
N.T.S.

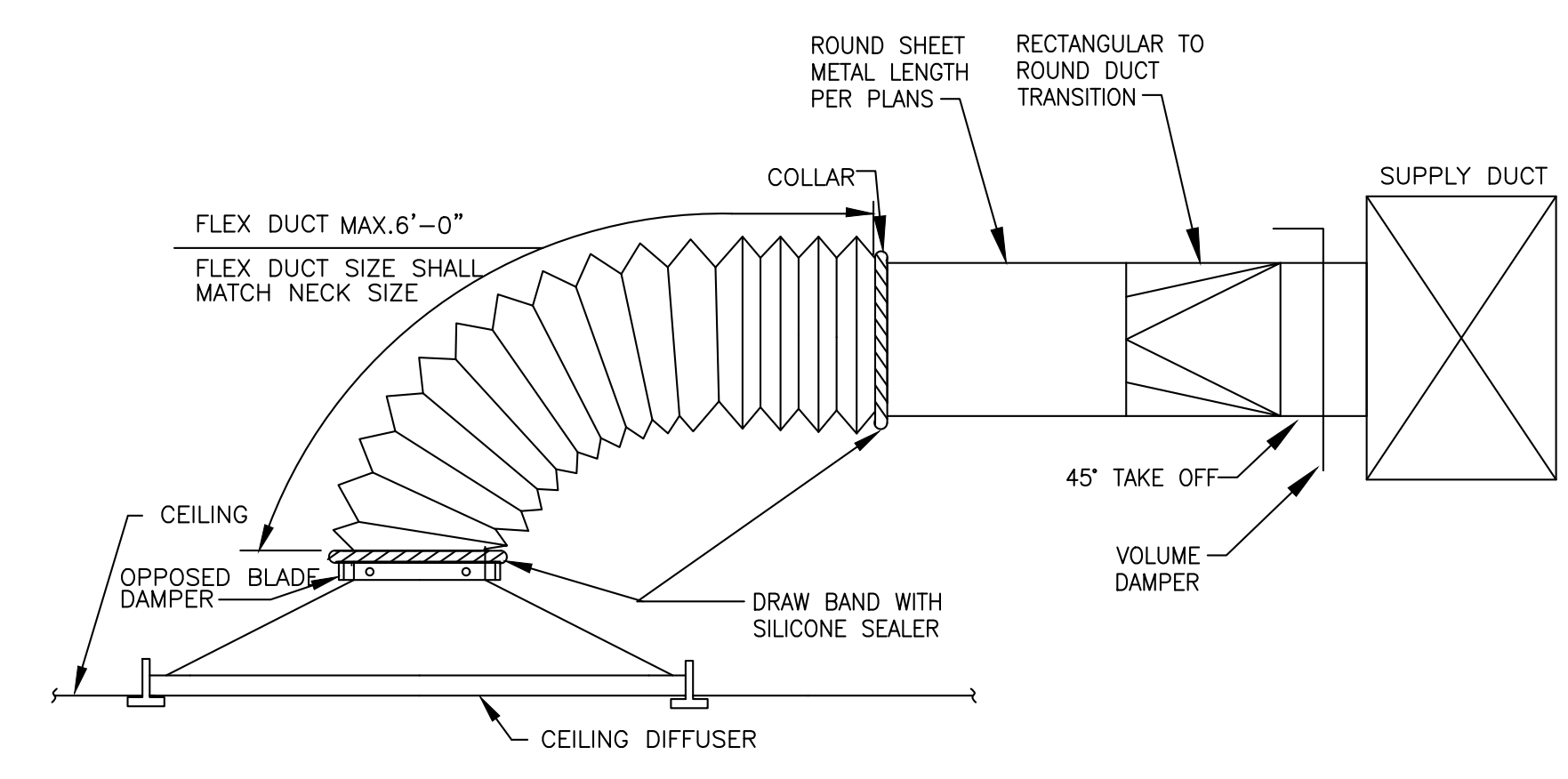

TYPICAL DIFFUSER CONNECTION
(SIDE OF DUCT CONNECTION)

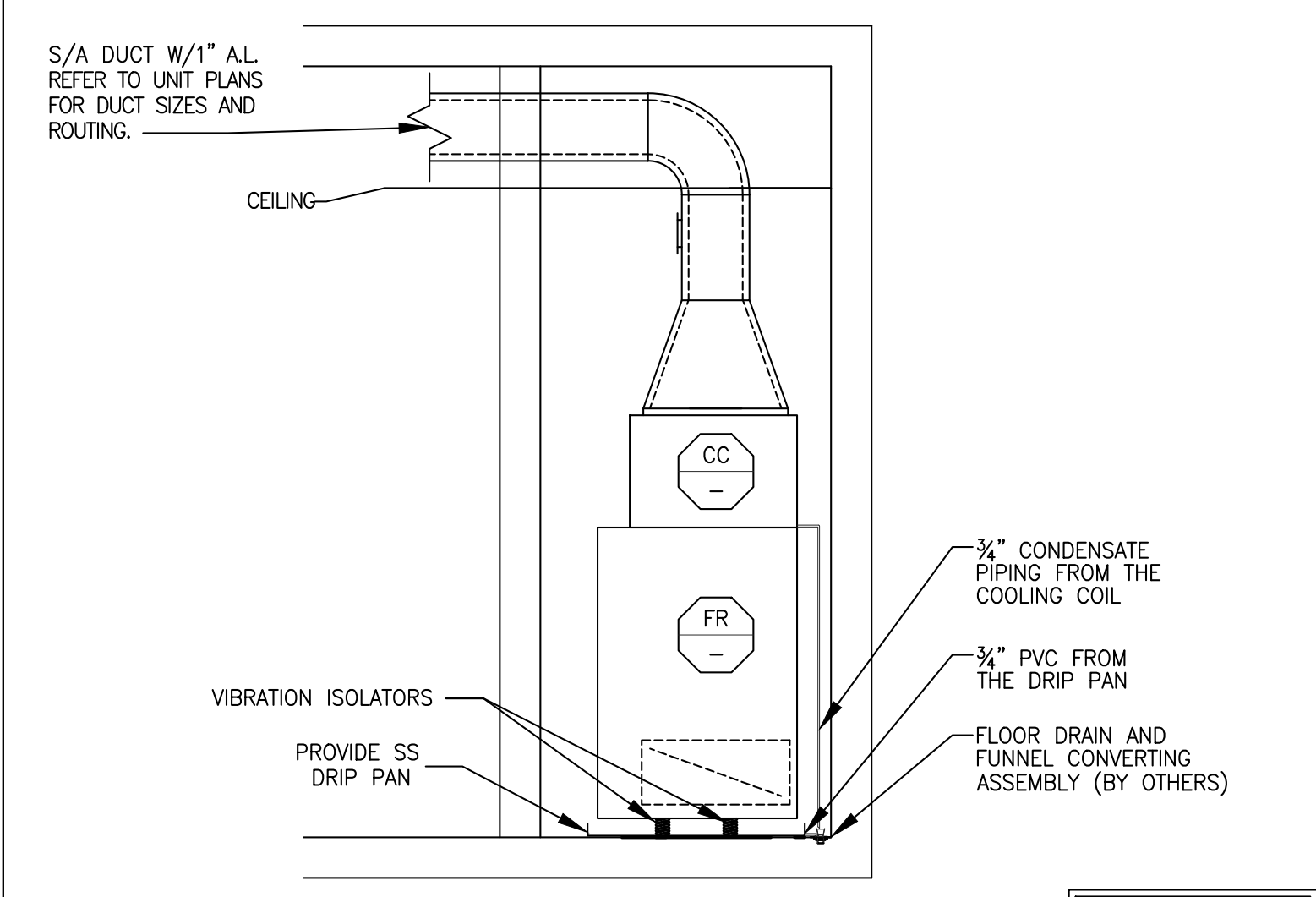

TYPICAL FR CLOSET DETAIL
N.T.S.

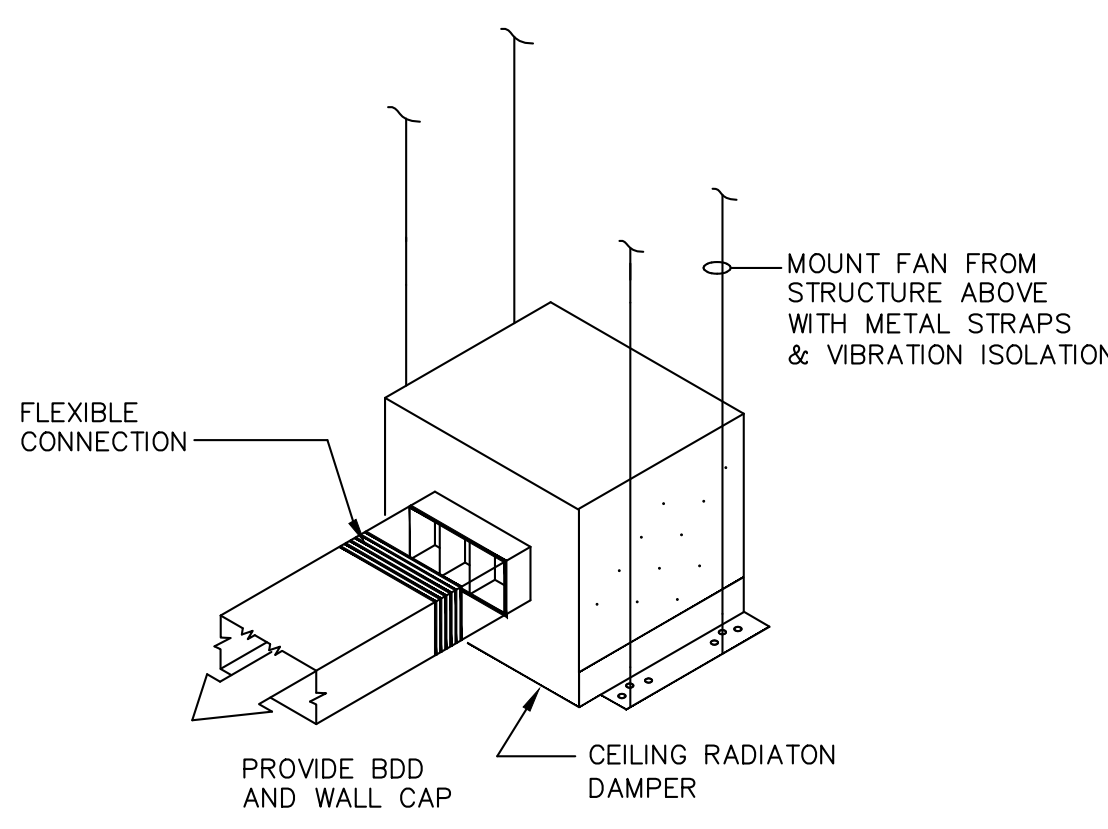

TOILET/KITCHEN EXHAUST FAN INSTALLATION DETAIL
NOT TO SCALE

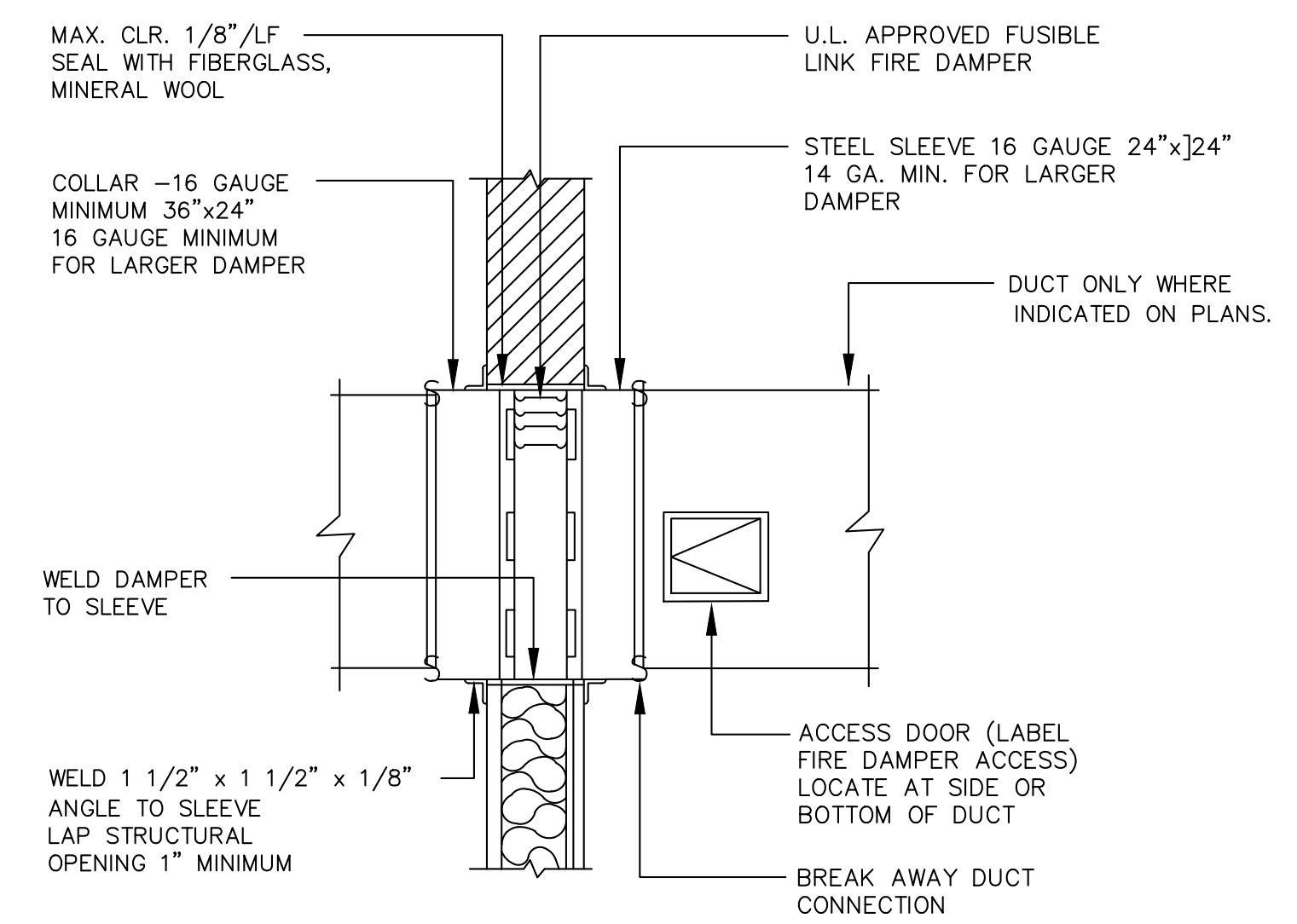

FIRE DAMPER DETAIL
NOT TO SCALE

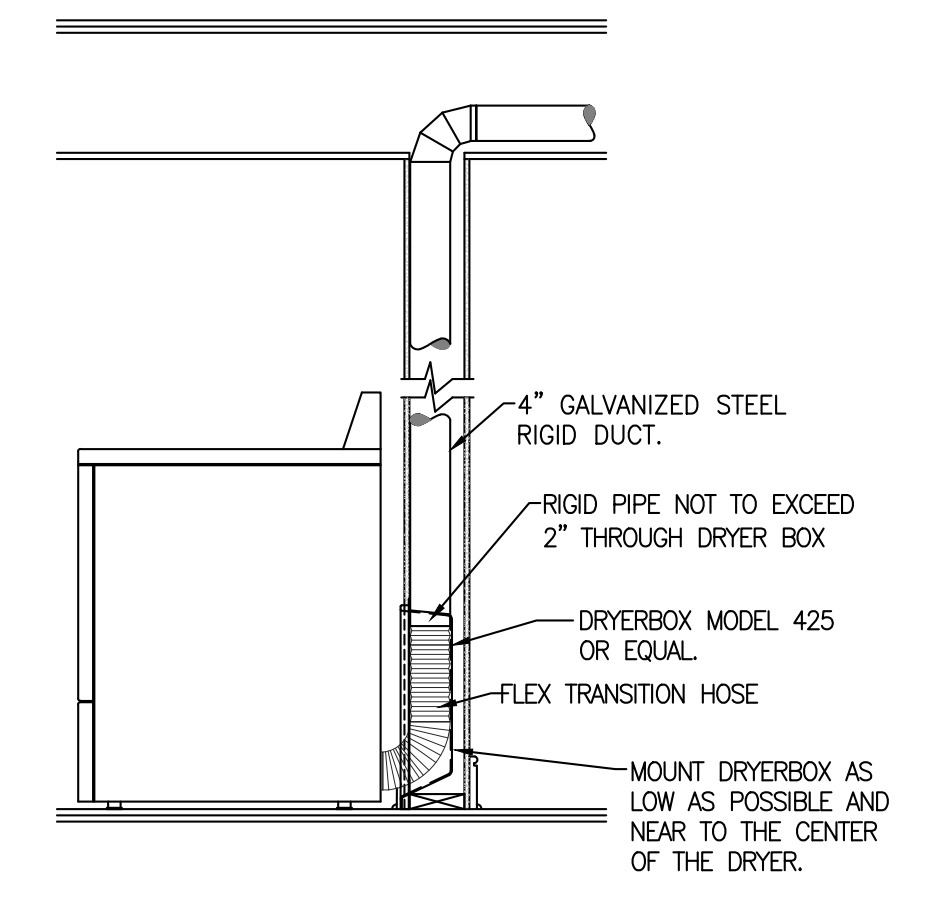

CLOTHES DRYER BOX DETAIL
NOT TO SCALE

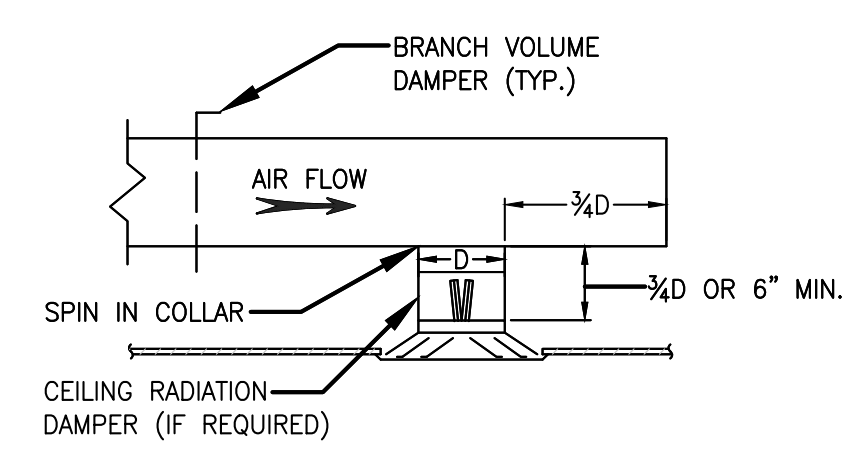

TYPICAL DIFFUSER INSTALLATION
NOT TO SCALE

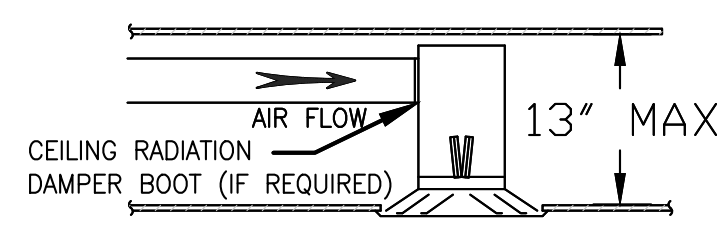

TYPICAL DIFFUSER INSTALLATION
NOT TO SCALE

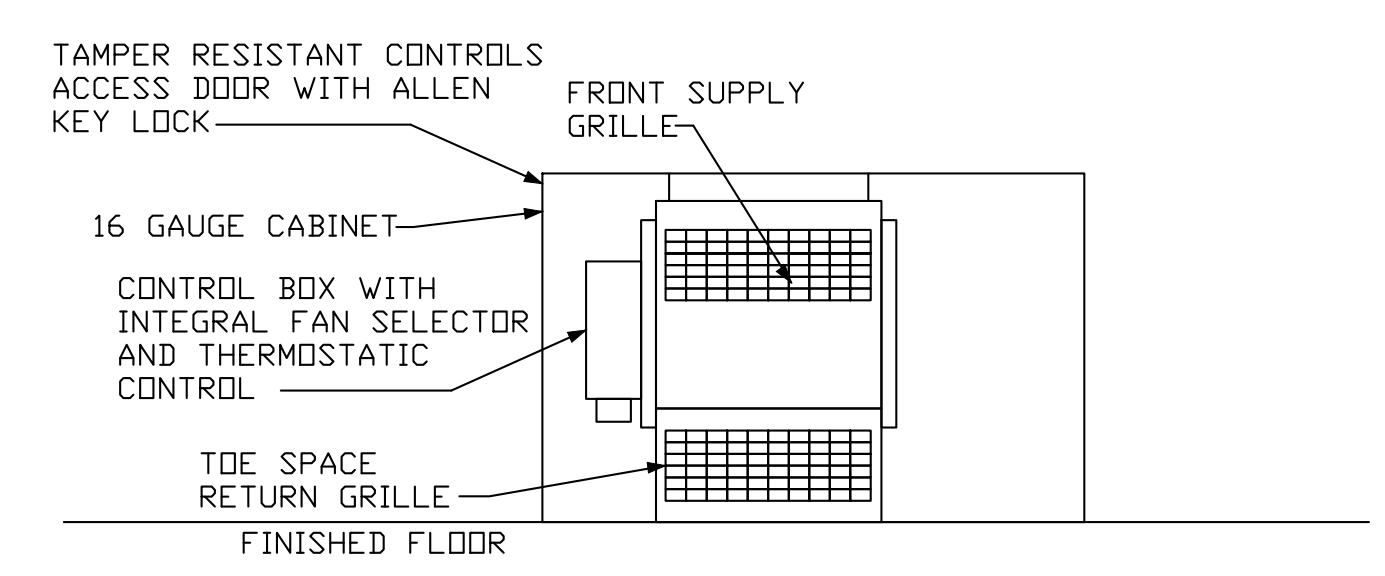

ELECTRIC CABINET UNIT HEATER
N.T.S.

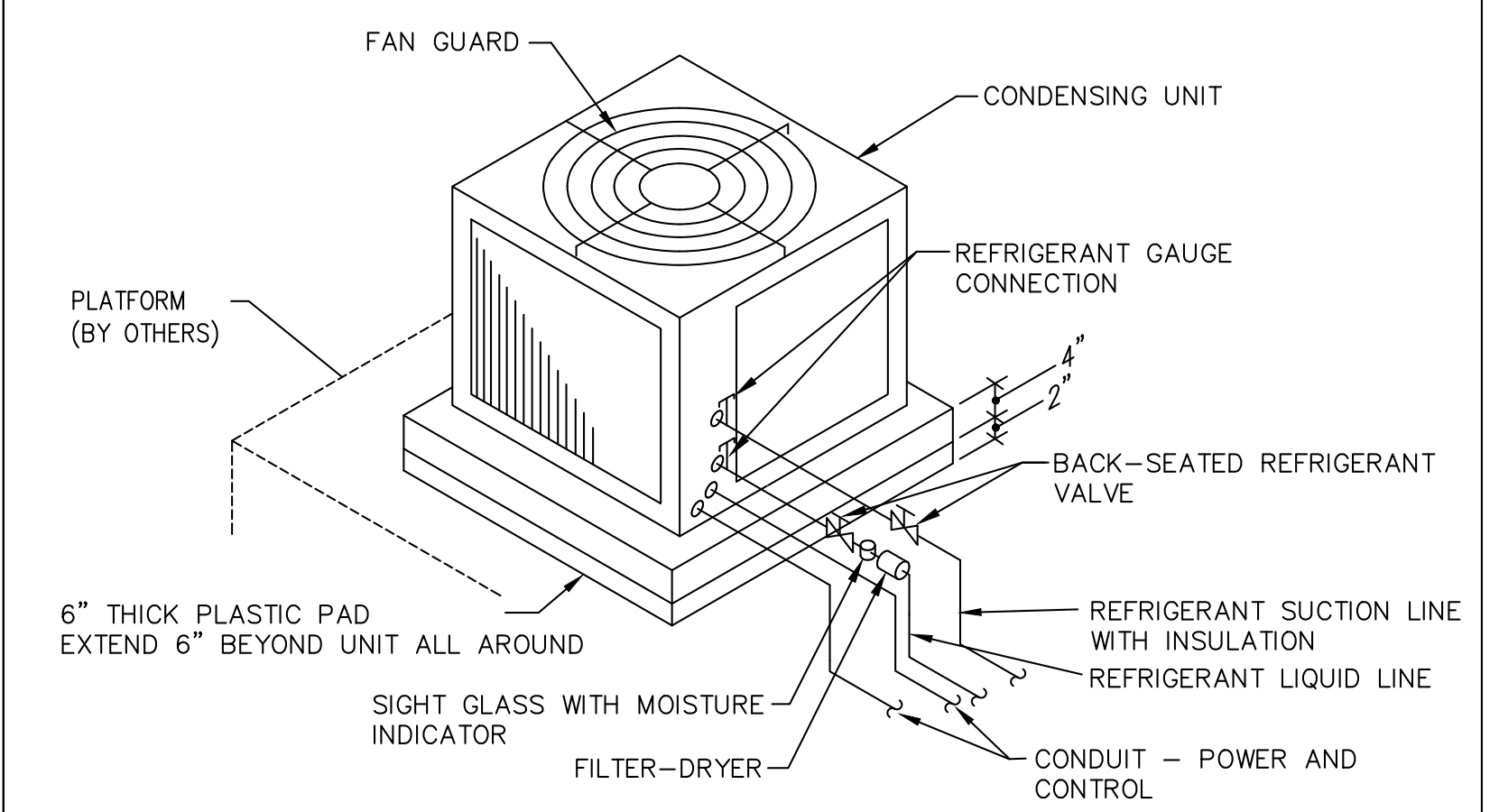

CONDENSING UNIT - ON PLATFORM
N.T.S.



Paterson Habitat For Humanity
146 North 1st Street
Paterson, NJ 07522

PROJECT NAME

135 SUMMER STREET
PASSAIC, NJ

CHEN O'NEIL ARCHITECTS, PLLC

29 GANUNG DRIVE
OSSINING, NY 10562
646-812-5566



KEAO ENGINEERS
Engineering Excellence since 1984
186 WOOD AVE. SOUTH - 1ST FLOOR
ISSELIN, NJ 08850
TEL (732) 635 0044 • FAX (732) 635 1777

2 100% PERMIT SET 2/02/2021

1 80% DD SET 1/08/2021

ISSUE/REVISION DATE

DRAWING TITLE

**MECHANICAL
DETAILS**

DRAWING NO.

M-401

DATE: 12/01/20

SCALE: AS NOTED

STAMP & SIGNATURE

FURNACE SECTION (TRANE OR EQUAL)																			COOLING COIL SECTION (TRANE OR EQUAL)											AHU X					
TAG	AC UNIT	TONNAGE	INPUT CAPACITY (BTU/HR)	OUTPUT CAPACITY (BTU/HR)	TEMP. RISE (°F)		BLOWER FAN SECTION			VENT SIZE (ø")		FILTER		COMBUSTION FAN SECTION			ELECTRICAL			WEIGHT	MANUFACTURER MODEL NUMBER	AFUE	COOLING CAPACITY		CFM	FACE AREA (SQ FT)	PRESSURE DROP (IN)	NO. OF ROWS	FINS PER IN.	REF. LINE SIZE		WEIGHT	MANUFACTURER MODEL NO.	REMARKS	NOTES:
					MIN (1,2 STAGE)	MAX (1,2 STAGE)	CFM	EXT. S.P. (in)	MIN. MOTOR HP	FAI (ø")	FLUE (ø")	THICK (in)	DIM (in)	FLA	MIN. MOTOR HP	RPM (1 STAGE) (2 STAGE)	VOLTS/ PHASE	MIN. CIRCUIT AMPACITY(A)	MAX FUSE SIZE(A)				TOTAL CAPACITY (BTU/HR)	SENSIBLE CAPACITY (BTU/HR)						GAS	LIQUID				
AHU-1,2,3,4	ACCU-1,2,3,4	1.5	60,000	58,200	25 35	55 65	600	0.7	0.5	3"	3"	MERV8 1"	16 x 25	0.66	-	2600 3300	120/1	7.9	15	115	TRANE S9V2B060U3PSBA	96.0	19,200	14,200	600	3.50	0.2	3	14	3/4	3/8	50	TRANE 4TXCB003DS3	1-6	1. PROVIDE DISCONNECT SWITCH. 2. PROVIDE 7-DAY FULLY PROGRAMMABLE THERMOSTAT. 3. PROVIDE VIBRATION ISOLATORS. 4. PROVIDE STAINLESS STEEL DRIP PAN. 5. PROVIDE MERV 08 FILTER. 6. PROVIDE OVERALL REF. LINE LENGTH AND CONFIRM REF. LINE SIZES WITH MANUFACTURER.
AHU-5	ACCU-5	2.5	60,000	58,000	25 35	55 65	1000	0.7	0.5	3	3	1	16 x 25	0.66	-	2600 3300	120/1	7.9	15	120	TRANE S9V2B060U3PSBA	96.0	29,818	22,713	1000	5.0	0.2	3	12	7/8	3/8	50	TRANE 4TXCB004DS3	1-6	
AHU-6,7	ACCU-6,7	3.0	60,000	58,000	25 35	55 65	1200	0.7	0.75	3	3	1	16 x 25	0.66	-	2600 3300	120/1	10.8	15	125	TRANE S9V2B060U4PSBA	96.0	36,226	27,859	1200	6.0	0.3	3	14	7/8	3/8	60	TRANE 4TXCB006DS3	1-6	

SPLIT SYSTEM CONDENSING UNIT (TRANE OR EQUAL)																			ACU X		
TAG	COOLING COIL	COOLING CAPACITY		COMPRESSOR			CONDENSER FAN SECTION			ELECTRICAL					REF. LINE SIZE		WEIGHT	MANUFACTURER MODEL NUMBER	SEER	REMARKS	NOTES:
		TOTAL CAPACITY (BTU/HR)	SENSIBLE CAPACITY (BTU/HR)	RLA	LRA	REFRIG	DIA (in)	MIN. MOTOR HP	FLA	MCA	MAX FUSE SIZE (AMPS)	VOLTS	PHASE	Hz	GAS	LIQUID					
ACCU-1,2,3,4	AHU-1,2,3,4	19,200	14,200	9.0	63.0	R-410A	18.2	1/15	0.6	12.0	20	208	1	60	3/4	3/8	150	4TTR4018L1	15.0	NOTES 1-2	1. PROVIDE DISCONNECT SWITCH 2. PROVIDE VIBRATION ISOLATORS.
ACCU-5	AHU-5	29,818	22,713	12.8	68.0	R-410A	23	1/8	0.64	17.0	25	208	1	60	3/4	3/8	160	4TTR4031L1	15.75	NOTES 1-2	
ACCU-6,7	AHU-6,7	36,000	27,300	14.1	72	R-410A	23	1/8	0.64	18.0	30	208	1	60	3/4	3/8	160	4TTR4037L1	15.25	NOTES 1-2	

TOILET EXHAUST FANS															SF X	MAU X	EF X	KEF X	TX X
UNIT ID	MANUFACTURER MODEL NUMBER	TYPE	LOCATION	SERVING AREA	INTERLOCKED WITH	CFM	SP IN. WG.	DRIVE	MOTOR HP	ELECTRICAL			WEIGHT (LBS.)	NOTES					
										VOLTS	PHASE	HERTZ							
TX-1	PANASONIC FV-0511VKSLL2	CABINET CEILING FAN	CEILING	TOILET	OCCUPANCY SENSOR	50/75	0.125	DIRECT	1/2	115	1	60	15	NOTES 1-4,6					
EF-1	GREENHECK SQ-80-VG	INLINE	ABOVE CEILING KITCHEN	TOILETS	TIME-CLOCK	225	0.5	DIRECT	1/2	115	1	60	50	NOTES 1-3					
KEF-1	CAPTIVEAIRE SIF11DD	INLINE MIXED FLOW	STORAGE	KITCHEN HOOD	HEAT SENSOR / MANUAL	855	0.75	BELT	1	208	3	60	160	NOTES 1-3,5					
SF-1	FANTECH FG 8XL	INLINE	MECH. ROOM	AHU-5	AHU-5	250	0.5	DIRECT	1/10	115	1	60	10	NOTES 1-3					
SF-2	FANTECH FG 8XL	INLINE	MECH. ROOM	AHU-6,7	AHU-6,7	350	0.5	DIRECT	1/10	115	1	60	10	NOTES 1-3					
MAU-1	GREENHECK SQ-98-VG	INLINE	ABOVE CEILING MECH. ROOM	KITCHEN HOOD	KEF-1	684	0.5	DIRECT	3/4	208	1	60	42	NOTES 1-3					

INDOOR HEAT PUMP/AC UNITS											AC -	
TAG	SERVICE AC UNIT	COOLING CAPACITY (BTU/HR)	HEATING CAPACITY (BTU/HR)	CFM	ELECTRICAL				WEIGHT (LBS)	MANUFACTURER & MODEL NUMBER	REMARKS	NOTES:
					VOLTS	PHASE	MCA (A)	BREAKER SIZE (A)				
AC-1	KITCHEN	24,000	27,000	537	FROM OUTDOOR UNIT				30	LG ARNU243SKA4	NOTES 1-4	1. PROVIDE UNIT MOUNTED DISCONNECT SWITCH. 2. PROVIDE WALL MOUNTED THERMOSTAT. 3. PROVIDE DPLS1 CONDENSATE OVERFLOW SENSOR. 4. REFER TO MANUFACTURER RECOMMENDATION FOR PIPE SIZING, INSULATION AND LENGTHS, INSTALL AS PER MANUFACTURER RECOMMENDATION.

AIR COOLED CONDENSING UNIT														CU -			
TAG	SERVICE AC UNIT	RATED CAPACITY		FAN	ELECTRICAL				REFRIGERANT	REF. LINE SIZE		WEIGHT (LBS)	MANUFACTURER & MODEL NUMBER	EER SEER	HSPF	REMARKS	NOTES:
		COOLING	HEATING		AIRFLOW PER FAN (CFM)	VOLTS	PHASE	MCA		MOCP	HIGH PRESSURE						
CU-1	AC-1	24,000	27,000	2,119	208	1	19.6	30	R-410A	3/8	5/8	160	LG ARUN024GSS4	10.70 17.00	10.0	1-4	1. PROVIDE UNIT MOUNTED DISCONNECT SWITCH. 2. PROVIDE FIELD INSTALLED SUPPORTS. SUPPORTS SHOULD BE PROVIDED WITH NEOPRENE PADS. 3. ADDED FIELD CHARGE MUST BE UPDATED BASED UPON FINAL AS-BUILD PIPING LAYOUT. 4. REFER TO MANUFACTURER RECOMMENDATION FOR PIPE SIZING, INSULATION AND LENGTHS, INSTALL AS PER MANUFACTURER RECOMMENDATION.



PROJECT NAME
**135 SUMMER STREET
PASSAIC, NJ**

CHEN O'NEIL ARCHITECTS, PLLC

29 GANUNG DRIVE
OSSINING, NY 10562
646-812-5566



2	100% PERMIT SET	2/02/2021
1	80% DD SET	1/08/2021

ISSUE/REVISION DATE
MECHANICAL SCHEDULES

DRAWING NO.
M-601

DATE: **12/01/20**
SCALE: **AS NOTED**

STAMP & SIGNATURE

AIR TERMINALS (APARTMENTS 2ND FLOOR)					
TAG	DUCTED / NON-DUCTED				
	TYPE	CFM RANGE	NECK SIZE	NOMINAL FACE SIZE	MODEL
CD-1	SUPPLY DIFFUSER	0 - 200	8"ø	12 X 6	HART & COOLEY A303
RG-1	RETURN GRILLE	0 - 600	12 X 12	24 X 24	HART & COOLEY A650

NOTE:

- BORDER TYPE TO BE COMPATIBLE WITH SURFACE TYPE.
- COLOR AND FINISH TO BE REVIEWED AND APPROVED BY THE ARCHITECT.
- PROVIDE CABLE OPERATED DAMPER LOCATED IN THE BRANCH, OPERABLE THROUGH THE FACE OF THE DIFFUSER (KEY OPERATED) OR NECK OPERATED DAMPER.
- PROVIDE CRD IN ALL FIRE-RATED CEILINGS.

ELECTRIC DUCT HEATERS												
(NEPTRONIC BASIS OF DESIGN)												
UNIT NO.	SERVICE	HEATER TYPE	KW	DUCT DIMENSION (INSIDE INCHES)		POWER SUPPLY LINE		NO. OF HEATING STAGES	CONTROL CIRCUIT VOLTAGE	DESIGN AIRFLOW (CFM)	MODEL	REMARKS
				WIDTH	HEIGHT	VOLTS	PHASE					
EDH-1	MAU-1	OPEN COIL, INSERT	12	14	14	208	3	MODULATING	24	684	DF C100H	1-15

NOTES:

- INTERLOCK DUCT HEATER WITH MAU-1.
- DUCT-MOUNTED SUPPLY AIR SENSOR TO MAINTAIN LAT OF 75°F (ADJ.).
- FULL BREAK CONTACTOR.
- MAGNETIC CONTACTOR.
- STAGE FUSE.
- DISCONNECT SWITCH.
- AUTOMATIC THERMAL CUTOUT.
- MANUAL THERMAL CUTOUT.
- TRANSFORMER.
- TRANSFORMER FUSE.
- CONTROL FUSE.
- ELECTRONIC AIRFLOW SENSORS.
- NEPTRONIC CONTROLLER.
- CONTROL PANEL NEMA 1.
- CONTROL BOX.

AIR TERMINALS (1ST FLOOR)					
TAG	DUCTED / NON-DUCTED				
	TYPE	CFM RANGE	NECK SIZE	NOMINAL FACE SIZE	MODEL
EG-1	EXHAUST GRILLE	0 - 75	6 X 6	12 X 12	TITUS 355 FL
CD-1	SUPPLY DIFFUSER	0 - 100	6"ø	12 X 12	TITUS TMSA
CD-2	SUPPLY DIFFUSER	0 - 150	8"ø	24 X 24	TITUS TMSA
CD-3	SUPPLY DIFFUSER	0 - 350	12"ø	24 X 24	TITUS TMSA
RG-1	RETURN GRILLE	0 - 100	12 X 18	18 X 18	TITUS 355 FL
RG-2	RETURN GRILLE	0 - 2400	14 X 20	36 X 20	TITUS 355 FL
RG-3	RETURN GRILLE	0 - 300	8 X 8	12 X 12	TITUS 355 FL

NOTE:

- BORDER TYPE TO BE COMPATIBLE WITH CEILING TYPE.
- COLOR AND FINISH TO BE REVIEWED AND APPROVED BY THE ARCHITECT.
- PROVIDE VOLUME BRANCH DAMPER. WHERE LOCATED IN INACCESSIBLE AREAS, PROVIDE CABLE OPERATED DAMPER LOCATED IN THE BRANCH, OPERABLE THROUGH THE FACE OF THE DIFFUSER (KEY OPERATED).
- PROVIDE CRD IN ALL FIRE-RATED CEILINGS.

VENTILATION SCHEDULE													
Outside Air Ventilation Room Requirements (Standard Case: International Mechanical Code-2015 Ventilation Rates)													
Zone Name	Zone Type	Occupancy Category	Zone Air Distribution Effectiveness	Zone Floor Area (sf)	Zone Population (# of People)	Primary Airflow Rate for Zone (CFM)	People OA Rate	Area Outdoor Air Rate	People Outdoor Air Flow Rate Required in this Zone	Area Outdoor Air Flow Rate Required in this Zone	Outdoor Airflow Rate in Breathing Zone (CFM)	Zone Outdoor Airflow Rate (CFM)	Primary Outdoor Air Fraction
			Ez	Az	Pz	Vpz	Rp	Ra	Rp*Pz	Ra*Az	Vbz=Rp*Pz+Ra*Az	Voz=Vbz/Ez	Zp=Voz/Vpz
MEETING	Multiple Zone System	Office Spaces	0.8	190	18	2400	5.00	0.06	90.00	11.40	101	127	0.05
OFFICE	Multiple Zone System	Office Spaces	0.8	85	2	300	5.00	0.06	10.00	5.10	15	19	0.06
STORAGE	Multiple Zone System	Storage Rooms	0.8	125	0	100	0.00	0.12	0.00	15.00	15	19	0.19
TOILET 1	Multiple Zone System	Toilet Rooms And Bathrooms - Interm.	0.8	30	0	50	0.00	0.00	0.00	0.00	0	0	0.00
TOILET 2	Multiple Zone System	Toilet Rooms And Bathrooms - Interm.	0.8	38	0	50	0.00	0.00	0.00	0.00	0	0	0.00
TOILET 3	Multiple Zone System	Toilet Rooms And Bathrooms - Interm.	0.8	38	0	50	0.00	0.00	0.00	0.00	0	0	0.00
MECHANICAL	Multiple Zone System	Electrical Equipment Rooms	0.8	110	0	100	0.00	0.06	0.00	6.60	7	8	0.08
STORAGE	Multiple Zone System	Occupiable Storage Rooms	0.8	150	0	100	0.00	0.12	0.00	18.00	18	23	0.23
VESTIBULE	Multiple Zone System	Corridors	0.8	50	0	50	0.00	0.06	0.00	3.00	3	4	0.08
CORRIDOR	Multiple Zone System	Corridors	0.8	110	0	100	0.00	0.06	0.00	6.60	7	8	0.08
Total:	-	-	-	926	20	3300	-	-	100.00	65.70	166	207	-
Multiple Zone System:													
System Population Ps=	20												
Occupant Diversity D=	1.00												
Max Zp=	0.23												
Ez=	0.9												
Vou (Sum of Vbz)=	166												
Outdoor Air Intake Flow Rate Vot	184												

ELECTRIC BASEBOARD HEATER						
(QMARK)						
TAG	TOTAL KW	VOLTS/PH	LENGTH (FEET)	WATTS/FT	MODEL	NOTES
BB-1	0.75	120/1	3 FT	250	2513	1-3

NOTE:

- COLOR AND FINISH TO BE REVIEWED AND APPROVED BY THE ARCHITECT.
- PROVIDE BUILT-IN THERMOSTAT AND DISCONNECT.
- PROVIDE FLOOR MOUNTING PEDESTALS AS REQUIRED.
- PROVIDE FILLER SECTIONS AS REQUIRED.

CABINET/UNIT/ PLENUM HEATERS											
NO.	MAKE	MODEL	KW	VOLTS	PHASE	AMPS	CB SIZE AMPS	THERMOSTAT	DISC. SW.	MOUNTING	NOTES
CH-1	BERKO	FRC4024F	3.0	208	1	14.4	20	UNIT MOUNTED TAMPER PROOF	YES	WALL MOUNTED	NOTES 1-4

NOTES:

- PROVIDE UNIT MOUNTED DISCONNECT SWITCH.
- HEATER SHALL INCLUDE A THERMAL OVERLOAD PROTECTOR WITH MANUAL RESET.
- PROVIDE MOUNTING ACCESSORIES AS REQUIRED.
- PROVIDE RECESSED MOUNT FRAME.

AIR PURIFICATION SYSTEM										
TAG	FLOW	S/A FLOW	O/A FLOW	PRESSURE DROP (IN.WC)	VOLTAGE	MOUNTING LOCATION	MIN. ION DENSITY (IONS/CC)	MANUFACTURER AND MODEL	NOTES	
AP-1,2	CV	1200	175	0.05	24-240	DUCT	200 MILLION	GPS DM48-AC	1-4	

NOTES:

- PROVIDE DISCONNECT SWITCH.
- EQUIPMENT MUST PASS UL-867-2007 OZONE CHAMBER TESTING BY EITHER UL OR ETL.
- PROVIDE WITH SELF-CLEANING FEATURE.
- PROVIDE WITH WEATHERPROOF ENCLOSURE.



Paterson Habitat For Humanity
146 North 1st Street
Paterson, NJ 07522

PROJECT NAME

135 SUMMER STREET
PASSAIC, NJ

CHEN O'NEIL ARCHITECTS, PLLC

29 GANUNG DRIVE
OSSINING, NY 10562
646-812-5566

KEAO
ENGINEERS
Engineering Excellence since 1984
186 WOOD AVE. SOUTH, 1ST FLOOR
ISSELIN, NJ 08830
TEL (732) 635 0044 • FAX (732) 635 1777

2 100% PERMIT SET 2/02/2021

1 80% DD SET 1/08/2021

ISSUE/REVISION DATE

DRAWING TITLE

MECHANICAL
SCHEDULES

DRAWING NO.

M-602

DATE: 12/01/20

SCALE: AS NOTED

STAMP & SIGNATURE